

**ZOOMLION**

ZS0607E Series  
ZS0407E Series  
Operation and Safety Manual

Sep 2023 Version A



Zoomlion appreciates your choice of our machine for your application. The Operation and Safety Manual must be read and understood in its entirety before operating the machine.

This manual introduces you safety information, significant technical specs, safety operation in detail for working efficiency improving. Keep this manual properly at all times for looking up.

Do not operate the machine if there is any doubt in operation, please consult local service team for troubleshooting. Zoomlion AWP Machinery Company does not take the consequence of wrong operation.

This manual should be considered a permanent part of your machine and should remain with the machine at all times.

The content is under intellectual property protection, permission is required for a copy or other application.

There might be some tiny differences in details between your machine and the upgraded one due to the continuous improving. For clarification, questions, or additional information regarding any portions of this manual, Contact Zoomlion AWP Machinery.

Our company reserves the right to modify this manual as technical improvement without notice.

Thank you for your trust and support for Zoomlion products!

Zoomlion Intelligent Access Machinery Co.,Ltd.

This manual has the following safety precaution icons:

**⚠ DANGER**

Failure to comply with the safety precautions listed in this manual could result in personal injury or death.

**⚠ WARNING**

Failure to comply with the safety precautions listed in this manual could result in potential personal injury or death.

**⚠ CAUTION**

Failure to comply with the safety precautions listed in this manual could result in potential mild personal injury.

**NOTICE**

Indicates risks unrelated with personal injury (such as property damage).

<b>Foreword</b> .....	<b>I</b>
<b>Safety Precaution Icons</b> .....	<b>II</b>
<b>Contents</b> .....	<b>III</b>
<b>SECTION 1 SAFETY PRECAUTIONS</b> .....	<b>1-1</b>
1.1 General.....	1-1
1.2 Pre-operation.....	1-1
1.3 Hazard Classification.....	1-2
1.4 Intended Use .....	1-2
1.5 Safety Alert Symbols and Maintenance.....	1-2
1.6 Safety Operation .....	1-5
1.6.1 Operator safety .....	1-5
1.6.2 Workplace safety .....	1-5
1.6.2.1 Electric shock hazard.....	1-5
1.6.2.2 Tip-over hazard.....	1-6
1.6.2.3 Crush hazard.....	1-9
1.6.2.4 Danger of operation on the slope .....	1-9
1.6.2.5 Fall off hazard.....	1-9
1.6.2.6 Collision hazard.....	1-10
1.6.2.7 Burn hazard.....	1-12
1.6.2.8 Explosion and fire hazard .....	1-12
1.6.2.9 Machine damage hazard .....	1-13
1.6.2.10 Component damage hazard.....	1-13
<b>SECTION 2 MACHINE COMPONENTS AND CONTROLS</b> .....	<b>2-1</b>
2.1 Machine Components.....	2-1
2.2 Machine Controller .....	2-3
2.2.1 Electronic control unit (ECU).....	2-3
2.2.2 Platform control unit (PCU) .....	2-4
<b>SECTION 3 MACHINE INSPECTION</b> .....	<b>3-1</b>
3.1 General.....	3-1
3.1.1 Pre-operation inspection fundamentals.....	3-1
3.1.2 Pre-operation inspection .....	3-1

3.2 Function Test.....	3-3
3.2.1 Function test fundamentals .....	3-3
3.2.2 Turn on the Power Switch .....	3-3
3.2.3 At the electronic controls.....	3-3
3.2.4 At the platform controls.....	3-5
3.2.5 Turn off the main power switch.....	3-9
3.3 Check the Liner Actuator .....	3-9
3.3.1 Check the lifting liner actuator .....	3-9
3.3.2 Check the lifting liner wear .....	3-10
3.4 Workplace Inspection .....	3-10
3.4.1 Workplace inspection fundamentals.....	3-10
3.4.2 Workplace inspection .....	3-11
3.4 Decal Inspection .....	3-12
<b>SECTION 4 OPERATION INSTRUCTION.....</b>	<b>4-1</b>
4.1 General.....	4-1
4.2 Machine Operation .....	4-1
4.2.1 Turn on/off main power switch .....	4-1
4.2.2 Emergency stop .....	4-2
4.2.3 Emergency lowering.....	4-2
4.2.4 Operation after usage.....	4-2
4.3 Operation from Ground.....	4-2
4.3.1 Start ground operation function .....	4-2
4.3.2 Adjust platform position.....	4-2
4.4 Operation from Platform .....	4-2
4.4.1 Start platform operation function.....	4-2
4.4.2 Adjust platform position .....	4-3
4.4.3 Steering.....	4-3
4.4.4 Drive .....	4-3
4.4.5 Drive speed selection.....	4-4
4.4.6 Load weight display.....	4-4
4.4.7 Platform AC power.....	4-4
4.4.8 Indoor and outdoor working mode selection .....	4-5
4.5 Operation on Slope .....	4-8

4.5.1 Driving on a slope.....	4-8
4.5.2 Operating on a slope .....	4-8
<b>4.6 Traction .....</b>	<b>4-9</b>
<b>4.7 Operation Code .....</b>	<b>4-11</b>
4.7.1 Operation indicator code.....	4-11
4.7.2 Platform overload .....	4-12
4.7.3 Battery level indicator.....	4-12
<b>4.8 Safety Arm and Guard Operation .....</b>	<b>4-13</b>
4.8.1 How to use the safety arm .....	4-13
4.8.2 How to fold guard.....	4-13
4.8.3 How to raise guard.....	4-13
4.8.4 Operation after usage.....	4-14
<b>4.9 Battery and Charger Operation .....</b>	<b>4-14</b>
4.9.1 Observe and obey .....	4-14
4.9.2 Charging the battery .....	4-14
4.9.3 Maintenance free battery .....	4-14
4.9.4 Standard battery .....	4-14
4.9.5 Dry battery filling and charging instructions .....	4-15
<b>4.10 Lithium-ion Battery and Charger Operation .....</b>	<b>4-15</b>
4.10.1 Observe and obey .....	4-15
4.10.2 Charging lithium-ion batttery .....	4-16
<b>4.11 Transport and Lift .....</b>	<b>4-16</b>
4.11.1 Observe and obey .....	4-16
4.11.2 Transport.....	4-17
4.11.3 Lift .....	4-18
 <b>SECTION 5 MAINTENANCE .....</b>	 <b>5-1</b>
<b>5.1 General.....</b>	<b>5-1</b>
5.1.1 Maintenance symbols legend.....	5-1
5.1.2 Pre-start inspection .....	5-1
5.1.3 Maintenance hazard.....	5-2
5.1.4 Body injury hazard .....	5-2
<b>5.2 Battery Maintenance .....</b>	<b>5-3</b>
<b>5.3 Regular Maintenance .....</b>	<b>5-3</b>

<b>SECTION 6 STORAGE AND EX-FACTORY TEST.....</b>	<b>6-1</b>
6.1 Storage Conditions.....	6-1
6.2 Ex-factory Test Items.....	6-1
<b>SECTION 7 TECHNICAL PARAMETER.....</b>	<b>7-1</b>
<b>SECTION 8 DISPOSAL.....</b>	<b>8-1</b>
8.1 Service life.....	8-1
8.2 Disposal.....	8-1
<b>APPENDIX:INSPECTION AND MAINTENANCE RECORD.....</b>	<b>a</b>



# **ZOOMLION**

**Operation and Safety Manual**

**Section 1 Safety Precautions**





## SECTION 1 SAFETY PRECAUTIONS

### 1. 1.1 General

To Owners/Users/Operators:

Zoomlion appreciates your choice of our machine for your application. Our number one priority is user safety, which is best achieved by our joint efforts. The following requirements need to be adhere to for the purpose of safety operating:

- a) Obey all user rules, job site regulations and governmental regulations.
- b) Read, understand and obey all operating instructions on the machine and in this manual.
- c) Keep good safety operating convention.
- d) Allow only those authorized and qualified personnel to operate the machine under the supervision of an experienced and qualified operator.
- e) An operator must not operate the machine if he has any doubts.

Zoomlion appreciates your choice of our machine for your application.

### 2. 1.2 Pre-operation

#### **⚠ DANGER**

**Failure to comply with the safety precautions listed in this manual could result in personal injury or death.**

**An operator must not operate the machine, only if:**

- a) He has learned and practiced the principles of safe machine operation contained in this operational manual.
  - 1) Avoid hazardous situations.
  - 2) Be aware of safety rules before further operation.
  - 3) Perform a pre-operation inspection at all times.
  - 4) Implement functional test before operating the machine at all times.
  - 5) Inspect job site.
  - 6) Only use the machine as it was intended.
- b) Read, understand and obey the manufacturer's instructions and safety rules—safety and operator's manuals and machine decals.

- c) Read, understand and obey employer's safety rules and worksite regulations.

- d) Read, understand and obey all applicable governmental regulations.
- e) The operator is properly trained to safely operate the machine.

### 3. 1.3 Hazard Classification

Decals on this machine use symbols, color coding, and signal words to identify the following:



**Safety alert symbol**—used to alert you to potential personal injury hazards. Obey all safety messages that follow this symbol to avoid possible injury or death.

#### **▲ DANGER**

Indicates a hazardous situation which, if not avoided, will result in death or serious injury. This decal will have a red background.

#### **▲ WARNING**

Indicates a hazardous situation which, if not avoided, could result in death or serious injury. This decal will have an orange background.

#### **▲ CAUTION**

Indicates a hazardous situation which, if not avoided, could result in minor or moderate injury. This decal will have a yellow background.

#### **NOTICE**

Indicates a property damage message. This decal will have a blue background.

### 4. 1.4 Intended Use

This machine is intended to be used only to lift personnel, along with their tools, and materials to an aerial work site.

### 5. 1.5 Safety Alert Symbols and Maintenance

Replace any missing or damaged safety signs. Keep operator safety in mind at all times. Use mild soap and water to clean safety signs. Do not use solvent-based cleaners because they may damage the safety sign material.





















				
Read operational manual	Read service manual	Crushing hazard	Crushing hazard	Collision hazard
				
Tip-over hazard	Tip-over hazard	Tip-over hazard	Tip-over hazard	Electrocution hazard
				
Electrocution hazard	Explosion hazard	Fire hazard	Burn hazard	Dermohemia hazard
				
Engage safety arm	Keep away from moving parts	Keep clear of outriggers and tires	Move machine to level ground	Close chassis tray
				
Lower the platform	Do not set up where it cannot be leveled with outriggers	Maintain required clearance	Compartment maintenance implement by trained and authorized personnel only	Use a piece of cardboard or paper to search for leaks

Figure 1-1 Symbol and hazard pictorials definitions

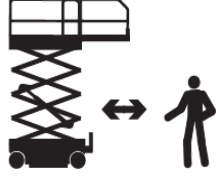



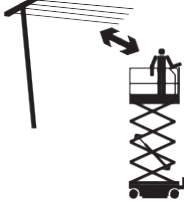





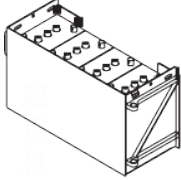

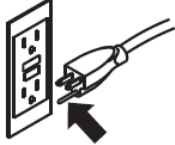
				
Batteries used as counterweights	Chock the wheels	Release brakes	3-wire grounded AC power supply only	Replace damaged wire and cable
				
Wheel load	Transporting diagram	Tie-down points	Lanyard anchorage points	No smoking
				
Voltage rating for power to platform	Pressure rating for air line to platform	Manual force	Wind speed	
				
Maximum capacity	Outdoor	Indoor		

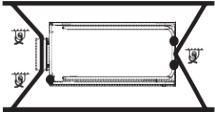
Figure 1-1 Symbol and hazard pictorials definitions

## 6. 1.6 Safety Operation

### 1.6.1 Operator safety

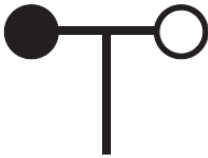
Personal fall protection equipment (PFPE) is required when operating this machine. If PFPE is required in job site or in operator's manual, following rules should be complied with:

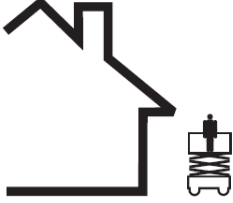
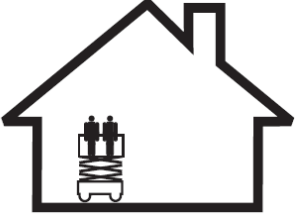
all PFPE must comply with applicable governmental regulations, and must be inspected and used in accordance with the PFPE manufacturer's instructions.

### 1.6.2 Workplace safety

#### 1.6.2.1 Electric shock hazard

#### **⚠ DANGER**

**This machine is not electrically insulated and will not provide protection from contact with or proximity to electrical current.**

- a) Obey all local and governmental regulations regarding required clearance from electrical power lines. Keep required clearance listed in Table 1-1.



**Table 1-1 Required clearance**

No.	Voltage	Required clearance
1	0 to 50KV	3.05 m/10ft
2	50 to 200KV	4.60 m/15ft
3	200 to 350KV	6.10 m/20ft
4	350 to 500KV	7.62 m/25ft
5	500 to 750KV	10.67m/35ft
6	750 to 1000KV	13.72m/45ft



- b) Allow for platform movement, electrical line sway or sag, and beware of strong or gusty winds.
- c) Keep away from the machine if it contacts energized power lines. Personnel on the ground or in the platform must not touch or operate the machine until energized power lines are shut off.



Do not operate the machine during lightning or storms.

Do not use the machine as a ground for welding.

### 1.6.2.2 Tip-over hazard

#### **⚠ DANGER**

- a) Occupants, equipment and materials shall not exceed the maximum platform capacity.

**Table 1-2 Rated load**

Model	Maximum Capacity	Capacity on Platform Extended
ZS0407E Series	240Kg/530 lbs	100kg/220 lbs
ZS0607E Series	230kg/510 lbs	113kg/250 lbs

- b) Do not elevate the platform unless the machine is on firm level ground.



- c) Do not depend on the tilt alarm as a level indicator. The tilt alarm sounds on the chassis only when the machine is on a severe slope.

If the tilt alarm sounds: use extreme caution to lower the platform with the emergency lowering pull

rod. Move the machine to a firm, level surface before lifting.

- d) Do not drive over 0.5mph (0.8km/h) with the platform raised.

Outdoor use: do not raise the platform when wind speeds may exceed 12.5 m/s (28 mph ). Lower the platform and stop operating the machine if the wind speed exceeds 12.5 m/s (28 mph ).

Indoor use: do not exceed the rated values of allowable manual force and maximum occupants listed in Table 1-3.

**Table 1-3 Maximum allowable manual force**

Model	Manual force	Maximum occupants
ZS0407E Series	400N/200N 90 lbs force /45 lbs force	2 (Indoor)/ 1 (Outdoor)
ZS0607E Series	400N/200N 90 lbs force /45 lbs force	2 (Indoor)/ 1 (Outdoor)

- e) Do not operate the machine in strong or gusty winds. Do not increase the surface area of the platform or the load. Increasing the area exposed to the wind will decrease machine stability.



- f) Use extreme care and slow speeds while driving the machine in the stowed position across uneven terrain, debris, unstable or slippery surfaces and nearholes and drop-offs.



- g) Do not drive the machine on or near uneven terrain, unstable surfaces or other hazardous conditions with the platform raised or extended.
- h) The following operations are prohibited at any circumstances:
  - 1) Push the machine or other objects with the platform.

- 2) Contact adjacent structures with the platform.
- 3) Tie the platform to adjacent structures.
- 4) Place loads outside the platform perimeter.
- 5) Operate the machine with the chassis trays open.
- 6) Push off or pull toward any object outside of the platform.



- i) Do not modify or alter an aerial work platform without prior written permission from the manufacture.
  - 1) Do not alter or disable the limit switches.
  - 2) Do not alter or disable machine components that in any way affect safety and stability.
  - 3) Do not replace items critical to machine stability with items of different weight or specification.
  - 4) Mounting attachments for holding tools or other materials onto the platform, toeboards, or guard rail system can increase the weight in the platform and the surface area of the platform or the load.
- j) Do not use lead acid or lithium-ion batteries that weigh less than the original equipment. Batteries are used as counterweight and are critical to machine stability.
  - 1) Each lithium-ion battery must weigh 30kg/66 lbs for ZS0407E-Li. Lithium-ion battery tray including batteries must weigh a minimum of 120kg/265 lbs.
  - 2) Each battery must weigh 25kg/55 lbs for ZS0407E. Battery tray including batteries must weigh a minimum of 140kg/309 lbs.
  - 3) Each battery must weigh 26kg/57 lbs for ZS0607E. Battery tray including batteries must weigh a minimum of 145kg/320 lbs.
- k) Do not place or attach fixed or overhanging loads to any part of this machine.
- l) Do not place ladders or scaffolds in the platform or against any part of this machine.



- m) Do not transport tools and materials unless they are evenly distributed and can be safely handled by person(s) in the platform.
- n) Do not use the machine on a moving or mobile surface or vehicle. Be sure the tires are in good condition and the lug nuts tightened, besides the opening pin installed in the right position.

### 1.6.2.3 Crush hazard

#### **⚠ DANGER**

- a) Keep hands and limbs out of scissors.
- b) Do not work under the platform or in the scissor links without the safety arm in place.
- c) Use common sense and planning when operating the machine with the controller from the ground. Maintain safe distances between the operator, the machine and fixed objects.

### 1.6.2.4 Danger of operation on the slope

#### **⚠ DANGER**

**Do not drive the machine on slopes that exceed its longitudinal and lateral ratings. Longitudinal and lateral ratings apply to machines in the stowed position.**

**Table 1-4 Longitudinal and lateral ratings for stowed position**

Model	Maximum longitudinal rating for the Stowed Position	Maximum lateral Rating for the Stowed Position
ZS0407E Series	30% (17°)	30% (17°)
ZS0607E Series	25% (14°)	25% (14°)

### 1.6.2.5 Fall off hazard

#### **⚠ DANGER**

**The guard rails system provides fall protection. If occupant(s) of the platform are required to wear personal fall protection equipment (PFPE) due to job site or employer rules, PFPE and its use shall be in accordance with the PFPE manufacturer's instructions and applicable governmental**

**requirements. Use approved lanyard attachment point provided.**

- a) Do not sit, stand or climb on the platform guard rails. Maintain a firm footing on the platform floor at all times.
- b) Do not climb down from the platform when raised.



- c) Keep the platform floor clear of debris.
- d) Do not enter or exit the platform unless the machine is in the stowed position.
- e) Attach the platform entry chain or close the entry gate before operating.
- f) Do not operate the machine unless the guard rails are properly installed and the entry is secured for operation.

**1.6.2.6 Collision hazard**

**⚠ DANGER**

**No stunt driving or horseplay while operating a machine.**

- a) Be aware of limited sight distance and blind spots when driving and operating.



- b) Be aware of extended platform position when moving the machine.
- c) Be sure the machine is on a level surface or secured before releasing the brake.
- d) Operators must comply with employer, job site, and governmental rules regarding use of personal protective equipment.
- e) Check the work area for overhead obstructions or other possible hazards.



- f) Be aware of crushing hazards when grasping the platform guard rail.



- g) Observe and use the color-coded direction arrows on the platform controls and the platform decal plate for drive and steer functions.
- h) Do not lower the platform unless the area below is clear of personnel and obstructions.



- i) Limit travel speed according to the condition of the ground surface, congestion, slope, location of personnel, and any other factors which may cause collision.



- j) Do not operate a machine in the path of any crane or moving overhead machinery unless the controls of the crane have been locked out and/or precautions have been taken to prevent any potential

collision.

### 1.6.2.7 Burn hazard

#### **⚠ DANGER**

a) Liquid or gas burn hazard.

- 1) Do not operate a machine with a hydraulic oil or air leak. An air leak or hydraulic leak can penetrate and/or burn skin.
- 2) Batteries contain acid. Always wear protective clothing and eye wear when working with batteries.



- 3) Avoid spilling or contacting battery acid. Neutralize battery acid spills with baking soda and water.
- 4) Do not expose the battery or charger in water or rain while charging.

#### **⚠ DANGER**

b) Electric shock or burn hazard.

- 1) Conduct daily check with wires and cables.



- 2) Change damaged items prior to operation. Avoid contact with battery terminals. Remove all rings, watches and jewelry.
- 3) Connect the battery charger to a grounded, AC 3-wire electrical outlet only.

### 1.6.2.8 Explosion and fire hazard

#### **⚠ DANGER**

- a) Do not operate the machine or charge the battery in hazardous locations or locations where potentially flammable or explosive gases or particles may be present.
- b) Keep sparks, flames, and lighted tobacco away from batteries. Batteries emit explosive gas.



- c) Swing out the charger tray when charging indoor for cooling.
- d) Do not use tools which could produce flames to contact battery terminals or cable clamp.
- e) Keep lithium-ion battery away from heat.
- f) Do not over charge or over discharge the lithium-ion battery.
- g) If there is heat, deformation, liquid leakage, odor or smoke when charging, stop using the lithium-ion battery and place the battery in an open place away from the crowd.
- h) It is strictly forbidden to immerse the lithium-ion battery in water, acid, alkaline and salt solution. Avoid rain.

#### 1.6.2.9 Machine damage hazard

##### **⚠ DANGER**

- a) Do not use a damaged or malfunctioning machine. Conduct a thorough pre-operation inspection of the machine and test all functions before each work shift.
- b) Immediately tag and remove from service a damaged or malfunctioning machine.
- c) Be sure all maintenance has been performed as specified in this manual and the appropriate Zoomlion service manual.
- d) Be sure all decals are in place and legible.
- e) Be sure operator's, safety, and responsibilities manuals are complete, legible, and in the storage container located on the machine.

#### 1.6.2.10 Component damage hazard

##### **⚠ DANGER**

- a) Do not use a charger other than the ZOOMLION charger.
- b) Use the appropriate number of people and proper lifting techniques when lifting batteries. Locked after each use.



# **ZOOMLION**

**Operation and Safety Manual**

**Section 2 Machine Components  
and Controls**





## SECTION 2 MACHINE COMPONENTS AND CONTROLS

### 7. 2.1 Machine Components

a) ZS0607E Series.

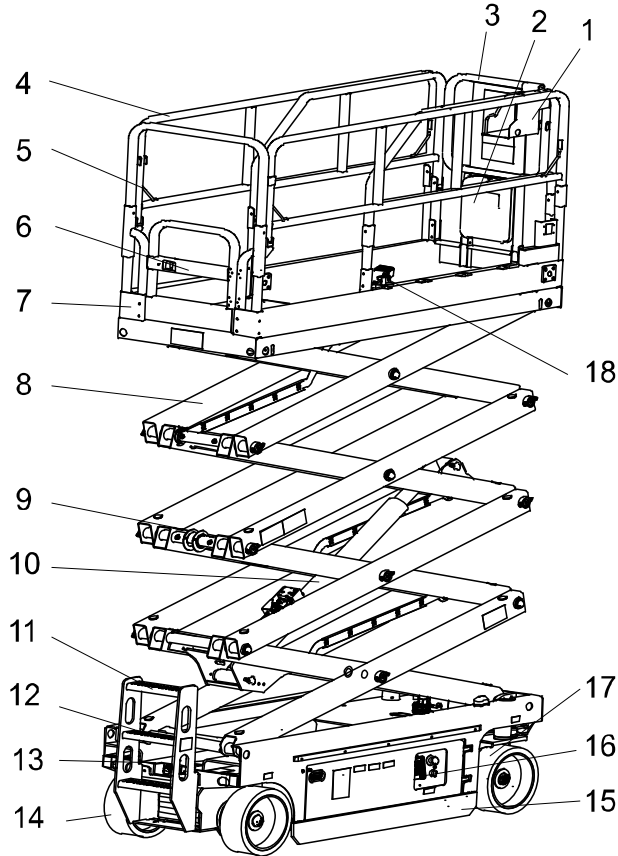

**Figure 2-1 Components 1**

**Table 2-1 Component instruction 1**

No.	Item	No.	Item	No.	Item
1	Platform Console	7	Fixed platform	13	Manual pump (HD series only)
2	Manual Storage Container	8	Scissor arm	14	Non-steering tire
3	Platform extension	9	Safety arm	15	Pothole guard
4	Platform guard rails	10	Lifting cylinder	16	Ground control
5	Lanyard anchorage points	11	Entry ladder	17	Steering wheel

6	Platform entry gate	12	Charger	18	Foot switch
---	---------------------	----	---------	----	-------------

b) ZS0407E Series.

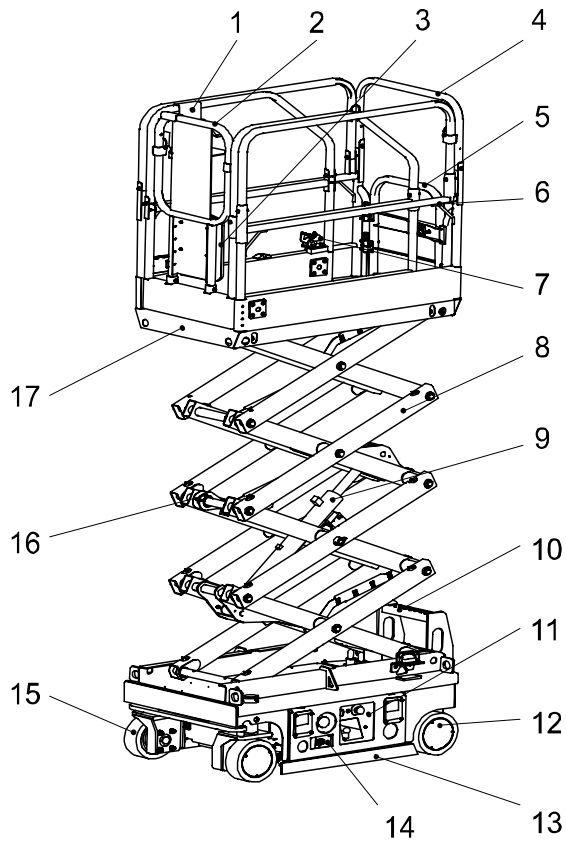

**Figure 2-2 Components 2**

**Table 2-2 Component instruction 2**

No.	Item	No.	Item	No.	Item
1	Platform Console	7	Foot switch	13	Pothole guard
2	Platform extension	8	Scissor arm	14	Charger
3	Manual Storage Container	9	Lifting linear actuator	15	Steering wheel
4	Platform guard rails	10	Entry ladder	16	Safety arm
5	Platform entry gate	11	Ground control	17	Fixed platform
6	Lanyard anchorage points	12	Non-steering tire		

## 8. 2.2 Machine Controller

## CAUTION

The manufacturer has no direct control over machine application and operation. The user and operator are responsible for conforming with good safety practices.

### 2.2.1 Electronic control unit (ECU)

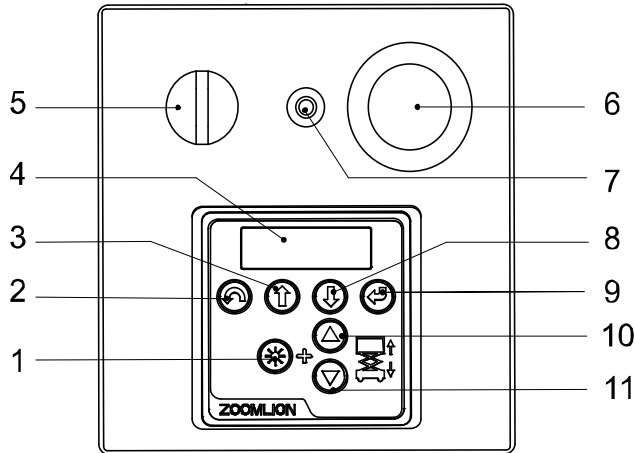

Figure 2-3 Electronic control Panel

Table 2-3 Electronic control panel instruction

No.	Item	No.	Item
1	Lifting enable button	7	10A breaker
2	Menu escape button	8	Menu down button
3	Menu up button	9	Menu enter button
4	LCD diagnostic readout	10	Platform up button
5	Key switch	11	Platform down button
6	Emergency stop switch		

a) Lifting enable button.

Press this button to activate lifting function.

b) Key switch.

Turn the switch to the platform position and the platform controls will operate. Turn the key switch to the off position and the machine will be off. Turn the key switch to the ground position and the electronic controls will operate.

c) Emergency stop switch.

Push in the Red Emergency Button to the off position to stop all functions. Pull out the Red Emergency Button to the on position to operate the machine.

**2.2.2 Platform control unit (PCU)**

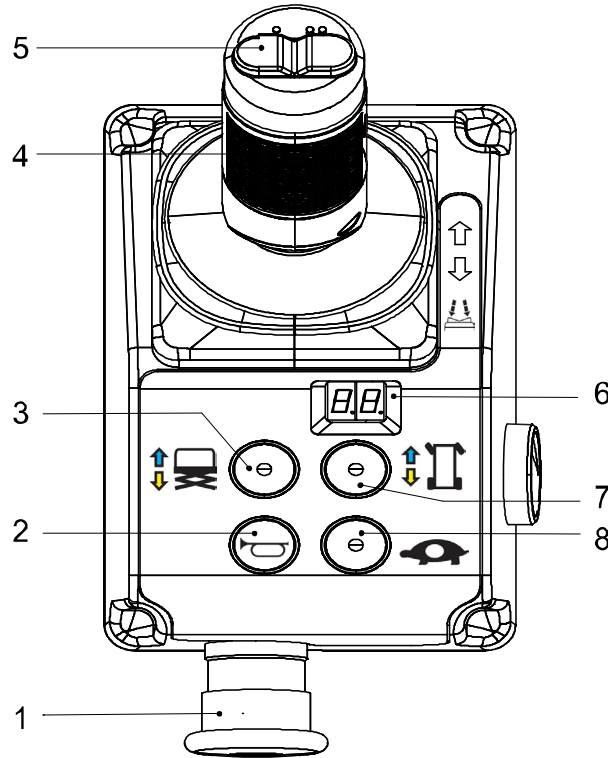

**Figure 2-4 Platform control panel**

**Table 2-4 Platform control panel instruction**

No.	Item	No.	Item
1	Emergency stop switch	5	Steering thumb button
2	Horn button	6	LED Readout
3	Lift function button	7	Drive function button
4	Control handle	8	Drive speed button

a) Emergency stop switch.

Push in the Red Emergency Button to the off position to stop all functions. Pull out the Red Emergency Button to the on position to operate the machine.

b) Horn button.

Press the horn button and the horn will sound. Release the horn button and the horn will not sound.



- c) Lift function button.

Push this button to activate the lift function. If the control handle is not moved within seven seconds, press the lift function button again.



- d) Proportional control handle and function enable switch for drive, steer and lift functions.

Lift function: press and hold the function enable switch to enable the lift function on the platform control handle. Move the control handle in the direction indicated by the blue arrow and the platform will raise. Move the control handle in the direction indicated by the yellow arrow and the platform will lower. The descent alarm should sound while the platform is lowering.

Drive function: press and hold the function enable switch to enable the drive function on the platform control handle. Move the control handle in the direction indicated by the blue arrow on the control panel and the machine will move in the direction that the blue arrow points. Move the control handle in the direction indicated by the yellow arrow on the control panel and the machine will move in the direction that the yellow arrow points.

- e) Thumb switch for steer function.

Press the left side of the thumb switch and the machine will turn in the direction the blue triangle points on the platform control panel. Press the right side of the thumb switch and the machine will turn in the direction the yellow triangle points on the platform control panel.



- f) LED readout for electric quantity indication and indicative operation code display.

- g) Drive function button.

Push this button to activate the drive function. If the control handle is not moved within seven seconds, press the lift function button again.

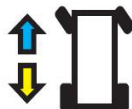

- h) Drive speed button.

- c) Press this button to activate the slow drive mode. The indicator light will illuminate when the slow drive mode is activated. Select this function in drive mode.





# **ZOOMLION**

**Operation and Safety Manual**

**Section 3 Machine Inspection**





## SECTION 3 MACHINE INSPECTION

### 9. 3.1 General

#### **⚠ DANGER**

**An operator must not operate the machine, only if he has learned and practiced the principles of safe machine operation contained in this operational manual.**

- d) Avoid hazardous situation.
- e) Perform a pre-operation inspection at all times.

**Know and understand the pre-operation inspection before going on to the next section.**

- f) Conduct functional test before usage.
- g) Inspect job site.
- h) Only use the machine as it was intended.

#### **3.1.1 Pre-operation inspection fundamentals**

- i) It is the responsibility of the operator to perform a pre-operation inspection and routine maintenance.
- j) The pre-operation inspection is a visual inspection performed by the operator prior to each work shift. The inspection is designed to discover if anything is apparently wrong with a machine before the operator performs the function tests.
- k) The pre-operation inspection also serves to determine if routine maintenance procedures are required. Only routine maintenance specified in this manual may be performed by the operator.
- l) Refer to the list on the next page and check each of the items.
- m) If damage or any unauthorized variation from factory delivered condition is discovered, the machine must be tagged and removed from service.
- n) Repairs to the machine may only be made by a qualified service technician, according to the manufacturer's specifications. After repairs are completed, the operator must perform a pre-operation inspection again before going on to the function tests.
- o) Scheduled maintenance inspections shall be performed by qualified service technicians according to the manufacturer's specifications and the requirements listed in the responsibilities manual.

#### **3.1.2 Pre-operation inspection**

- a) Be sure operation, safety, and responsibilities manuals are complete, legible, and in the storage container located on the machine.
- b) Be sure all decals are in place and legible. See Inspection section.

- c) Check the following components or areas for damage, improperly installed, or missing parts and unauthorized modification:
- 4) Electrical components, wiring, and electrical cables.
  - 5) Lifting linear actuator, steering linear actuator.
  - 6) Drive motors.
  - 7) Wearing pads.
  - 8) Tires and wheels.
  - 9) Alarm and indicator (if equipped).
  - 10) Nuts, bolts and other fasteners.
  - 11) Brake release components.
  - 12) Safety arm.
  - 13) Platform extension.
  - 14) Scissor pin and retaining fasteners.
  - 15) Platform joystick.
  - 16) Battery pack and connections.
  - 17) Platform entry chain or gate.
  - 18) Platform overload components.
  - 19) Pothole guards.
  - 20) Lanyard anchorage points.
  - 21) Check the machine for:
    - ① Cracks in welds or structural components
    - ② Dents or damage.
    - ③ Rust, corrosion, or oxidation.
- d) Be sure that all structural and other critical components are present and all associated fasteners and pins are in place and properly tightened.
- e) Be sure that the batteries are properly connected.
- f) Be sure that the hood is in place and locked after inspection.

**▲ CAUTION**

**If the platform must be raised to inspect the machine, make sure the safety arm is in place. See Operating Instruction section.**

## 10. 3.2 Function Test

### 3.2.1 Function test fundamentals

- a) The function tests are designed to discover any malfunctions before the machine is put into service. The operator must follow the step-by-step instructions to test all machine functions.
- b) A malfunctioning machine must never be used. If malfunctions are discovered, the machine must be tagged and removed from service. Repair to the machine may only be made by a qualified service technician, according to the manufacturer's specifications.
- c) After repairs are completed, the operator must perform a pre-operation inspection again before putting the machine into service.

#### **⚠ DANGER**

**An operator must not operate the machine, only if he has learned and practiced the principles of safe machine operation contained in this operational manual.**

- a) Avoid hazardous situations.
- b) Perform a pre-operation inspection at all times.
- c) Conduct functional test before usage.

**Know and understand the pre-operation inspection before going on to the next section.**

- d) Inspect job site.
- e) Only use the machine as it was intended.

### 3.2.2 Turn on the Power Switch

Pull out the red main power switch to on position which located on the side of battery container.



### 3.2.3 At the electronic controls

- a) Test emergency stop.
  - 1) Select a test area that is firm, level and free of obstruction.
  - 2) Be sure the batteries are connected.
  - 3) Pull out the platform and ground red Emergency Stop Button to the on position.
  - 4) Turn the key switch to electronic control.
  - 5) Observe the diagnostic LED readout on the platform controls. The LED should look like the picture below:

**CH**

- 6) Observe the diagnostic LCD readout on the electronic controls. The LCD should display the model and hour meter:

**Motor Hour Meter**  
**00000.0 h**

- 7) Push in the ground red Emergency Stop Button to off position.
- 8) Result: No function should operate.
- 9) Pull out the red Emergency Stop Button to the on position.
- b) Test the Up/Down functions.
- 1) This machine uses flashlights and buzzer warning.
  - 2) Descent alarm: the flashlight illuminates 60 times per minute. The descent alarm sounds at 60 beeps per minute.
  - 3) Descent delay alarm: the flashlight illuminates 120 times per minute. The descent alarm sounds at 120 beeps per minute.
  - 4) When the pothole guards have not deployed: the flashlight illuminates 120 times per minute. The descent alarm sounds at 120 beeps per minute.
  - 5) When the machine is not level: the flashlight illuminates 120 times per minute. The descent alarm sounds at 120 beeps per minute.
  - 6) Do not press the lift function enable button.
  - 7) Press the platform up or down button.
  - 8) Result: the lift function should not operate.
  - 9) Do not press the platform up or down button.
  - 10) Press the lift function enable button.
  - 11) Result: the lift function should not operate.
  - 12) Press and hold the lift function enable button and the platform up button.
  - 13) Result: the platform should raise.
  - 14) Press and hold the lift function enable button and platform down button.
  - 15) Result: the platform should lower.

The minimum distance between platform and ground should reach 2.3m/7ft 7in. Descent delay light will

illuminate and alarm will sound. Be sure there is no personnel or obstructions under the platform when lowering. Release and move the control handle to continue the lowering operation.

- c) Test emergency lowering.
  - 1) Activate the platform up function by pressing both the enable button and the platform up button, raise the platform to limit height.
  - 2) Cut off the power supply and press the emergency drop handle on one side of the drawer of the machine chassis.
  - 3) Result: Platform should lower with a speed not greater than 0.4m/s.

### 3.2.4 At the platform controls

- a) Test emergency stop.
  - 1) Select a test area that is firm, level and free of obstruction.
  - 2) Turn the key switch to platform control.
  - 3) Push in the platform red Emergency Stop Button to the off position.
  - 4) Result: no function should operate.
- b) Test the horn.
  - 1) Pull out the red Emergency Stop to the on position.
  - 2) Press the horn button.
  - 3) Result: the horn should sound.
- c) Test the Function Enable Switch and Up/Down function.
  - 1) Do not hold the function enable switch on the control handle.
  - 2) Slowly move the control handle in the direction indicated by the blue arrow, then in the direction indicated by the yellow arrow.
  - 3) Result: no function should operate.
  - 4) Press the lift function enable button.
  - 5) Wait seven seconds for the lift function to time out.



- 6) Slowly move the control handle in the direction indicated by the blue arrow, then in the direction indicated by the yellow arrow.
- 7) Result: the lift function should not operate.

- 8) Press the lift function enable button, the indicator lights up.
  - 9) Press and hold the function enable switch on the control handle when indicator lighting, and slowly move the control handle in the direction indicated by the blue arrow.
  - 10) Result: the platform should raise. The pothole guards should deploy.
  - 11) Release the control handle.
  - 12) Result: the platform should stop raising.
  - 13) Press and hold the function enable switch on the control handle when indicator lighting, and slowly move the control handle in the direction indicated by the yellow arrow.
  - 14) Result: the platform should lower.
- d) Test drive function button.
- 1) Press the drive function button, then the indicator lights up.

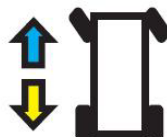

- 2) Wait seven seconds for the drive function to time out.
  - 3) Slowly move the control handle in the direction indicated by the blue arrow, then in the direction indicated by the yellow arrow.
  - 4) Result: no function should operate.
- e) Test the steering.

### **CAUTION**

**When performing the steer and drive function tests, stand in the platform facing the steer end of the machine.**

- 1) Press the drive function button, then the indicator lights up.

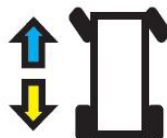

- 2) Press and hold the functional enable switch on the control handle when lighting.
- 3) Press the thumb rocker switch on top of control handle in the direction indicated by the blue triangle on the control panel.
- 4) Result: the steer wheels should turn in the direction indicated by the blue triangle.
- 5) Press the thumb rocker switch on top of the control handle in the direction indicated by the



yellow triangle on control panel.

- 6) Result: the steer wheels move towards the direction indicated by the yellow triangle.

f) Test driving and braking.

### CAUTION

**The brake must be able to hold the machine on any slope it is able to climb. This test is performed on the ground with a platform controller. Do not stand in the platform.**

- 1) Press the drive function button, then the indicator lights up.

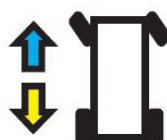

- 2) Press the function enable switch on the control handle when lighting.
- 3) Slowly move the control handle in the direction indicated by the blue arrow on the control panel until the machine begins to move, then return the control handle to the center position.
- 4) Result: the machine should move in the direction that the blue arrow points on the control panel, then come to an abrupt stop when the control handle is returned to the center position.
- 5) Slowly move the control handle in the direction indicated by the yellow arrow on the control panel until the machine begins to move, then return the control handle to the center position.
- 6) Result: the machine should move in the direction that the yellow arrow points on the control panel, then come to an abrupt stop when the control handle is returned to the center position.

g) Test the tilt sensor operation.

- 1) Fully lower the platform.
- 2) Place a 5×10cm/2×4in or similar piece of wood under both wheels on the side and drive the machine up onto them.
- 3) Raise the platform approximately 2.3m/ 7ft 7in from the ground.
- 4) Result: the platform should stop raising. The tilt alarm will sound and the light will illuminate. Platform controller LED readout displays LL, ground controller LCD displays LL: Machine Tilted.
- 5) Press the drive function button, then the indicator lights up.

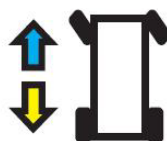

- 6) Press and hold the functional enable switch on the control handle.

- 7) Move the control handle in the direction indicated by the blue arrow, then move the control handle in the direction indicated by the yellow arrow.
  - 8) Result: the drive function should not work in either direction.
  - 9) Lower the platform and remove both pieces of wood.
- h) Test elevated drive speed.
- 1) Raise the platform approximately 2.3m/7ft 7in from the ground.
  - 2) Press the drive function button, then the indicator lights up.

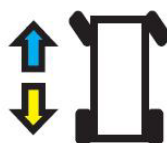

- 3) Press and hold the functional enable switch on the control handle. Slowly move the control handle to full drive position.
  - 4) Result: the maximum achievable drive speed with the platform raised should not exceed 22cm/9in per second.
  - 5) If the drive speed with the platform raised exceeds 22cm/9in per second, immediately tag and remove the machine from service.
- i) Test the pothole guards.

### **CAUTION**

**The pothole guards should automatically deploy when the platform is raised. The pothole guards activate limit switches that allow the machine to continue to function. If the pothole guards do not deploy, an alarm sounds and the machine will not drive or steer.**

- 1) Raise the platform.
- 2) Result: when the platform is raised 2.3m/7ft 7in from the ground, the pothole guards should deploy.
- 3) Press on the pothole guards on one side, and then the other.
- 4) Result: the pothole guards should not move.
- 5) Lower the platform.
- 6) Result: the pothole guards should return to the stowed position.
- 7) Place a 5×10cm/2×4in or similar piece of wood under a pothole guard.
- 8) Raise the platform.
- 9) Result: before the platform is raised 2.3m/7ft 7in from the ground, a warning light should

illuminate, and an alarm should sound. The platform controls LED readout should display 18 and the electronic controls LCD should display 18: Pothole Guard Fault.

- 10) Press the drive function button.

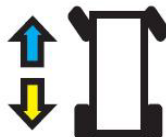

- 11) Press and hold the functional enable switch on the control handle.
- 12) Slow move the control handle in the direction indicated by the blue arrow, then in the direction indicated by the yellow arrow.
- 13) Result: the machine should not move forward or backward.
- 14) Press the drive function button, then the indicator lights up.
- 15) Press and hold the functional enable switch on the control handle.
- 16) Press the thumb rocker switch on top of the control handle in the direction indicated by the blue and yellow triangles on the control panel.
- 17) Result: the steer wheels should not turn left or right.
- 18) Lower the platform.
- 19) Remove the 5×10cm/2×4in or similar piece of wood.

### 3.2.5 Turn off the main power switch

When the machine has not been used for a long time, press the red Main Power Switch on the side of the battery box to the off position to turn off the main power.



## 11. 3.3 Check the liner actuator

### 3.3.1 Check the lifting liner actuator

The liner actuator can brake normally in working position is very important for the safety operation. Excessive wear of the motor brake pad may lead to brake failure. Through routine inspection, the inspector can determine the status of the liner actuator that may indicate problems with the motor brakes.

#### **CAUTION**

**Conduct the inspection when platform lifted.**

- a) Lift the device to a certain height through the ground control operation panel;

- b) Check test results: motor brake works normally, and the machine stop lifting and hold in the current position.
- c) Check if there is any abnormal shaking or sounds of liner actuator when lifting, if so, stop using the machine immediately and mark it.

### 3.3.2 Check the liner actuator wear

It is very important to check the wear of liner actuator ball screw regularly for the safe operation. Operating a machine with a severely worn ball screw can reduce machine performance and result in a potentially unsafe working condition.

The machine must perform this test on a firm, level and obstruction-free surface.

- a) Turn the key switch to the ground control, raise the platform to a height of about 2.4m above the ground, lift and move safety arm to the middle of the shaft sleeve of the shear fork, rotate downward to the vertical state, and lower the height of the platform until the safety arm is in complete contact with the shaft sleeve;
- b) Unscrew the grease filling port or observation port on the liner actuator;
- c) Check the wear of the ball screw through the feeding port or the observation port.
- d) Inspection results: ball screw wear within the normal range, no obvious shaking or abnormal sound.

## 12. 3.4 Workplace Inspection

### **⚠ DANGER**

**An operator must not operate the machine, only if: he has learned and practiced the principles of safe machine operation contained in this operational manual.**

- a) Avoid hazardous situations.
- b) Perform a pre-operation inspection at all times.
- c) Implement functional test before operation the machine at all times.
- d) Inspect job site

Know and understand the workplace inspection before going on to the next section.

- e) Only use the machine as it was intended.

### 3.4.1 Workplace inspection fundamentals

Workplace inspection helps the operator determine if the workplace is suitable for safe machine operation. It should be performed by the operator prior to moving the machine to the workplace. It is operator's responsibility to read and remember the workplace hazards, then watch for and avoid them while moving, setting up, and operating the machine.

### 3.4.2 Workplace inspection

Be aware of and avoid the following hazards:

- a) Drop-offs or holes.
- b) Bumps, floor obstructions or debris.
- c) Sloped surfaces.
- d) Unstable or smooth surfaces.
- e) Overhead obstructions and electric lines.
- f) Hazardous locations
- g) Inadequate surface support to withstand all load forces imposed by the machine.
- h) Wind and weather conditions.
- i) Unauthorized personnel.
- j) Other possible unsafe conditions.

### 13. 3.4 Decals Inspection

Use the lists and pictures below to verify that all decals are legible and in place.

**Table 3-1 Decal 1 (ZS0607E Series)**

NO.	Code	Item	Qty
1	00775207050401080	Label- Electrocutation Hazard	1
2	00775207050401050	Label- Lifting and Tying	4
3	007753070L0401020	Label- Wheel Load, 580kg/1280 lbs	4
4	00775207050401010	Label- Anti-pinch	4
5	00775207050403060	Label- Charger Power Supply	1
6	007753070N0401020	Label- Control Tray	1
7	00775207050401090	Label- Read the Instructions Carefully	2
8	007753070N0401030	Label- Max Driving Angle of Slope	1
9	00775207050402010	Label- Crushing and Safety Arm	2
10	00775207050403080	Label- Platform Power Rated Voltage	1
11	00775207050401040	Label- Forklift Hole	2
12	00775207050403020	Danger- Tip-over Hazard	1
13	00775207050403040	Label- Safety Rules and Tipping (Outdoor)	1
14	00775207050402060	Label- Max Manual Force (Outdoor)	1
15	00775207050402090	Label- non-insulated	1
16	00775207050403030	Label- CE	1
17	00775207050401030	Label- IPAF	1
18	007753070L0401050	Label- Capacity, 230kg/510 lbs (Outdoor)	1
19	00775207050403010	Danger- Crushing Hazard	1
20	007753070L0401060	Label- No High-pressure Water Flushing	2
21	00775207050403090	Label- Indoor and Outdoor Mode Switching	1
22	00775207050402050	Label- Handrail position	3
23	00775207050401060	Label- Lanyard Anchorage Point	4
24	00775207050403050	Label- Emergency Lowering	1
25	007753070L0401030	Label- Battery tray	1
26	00775207050402040	Label- AC Power to Platform	1

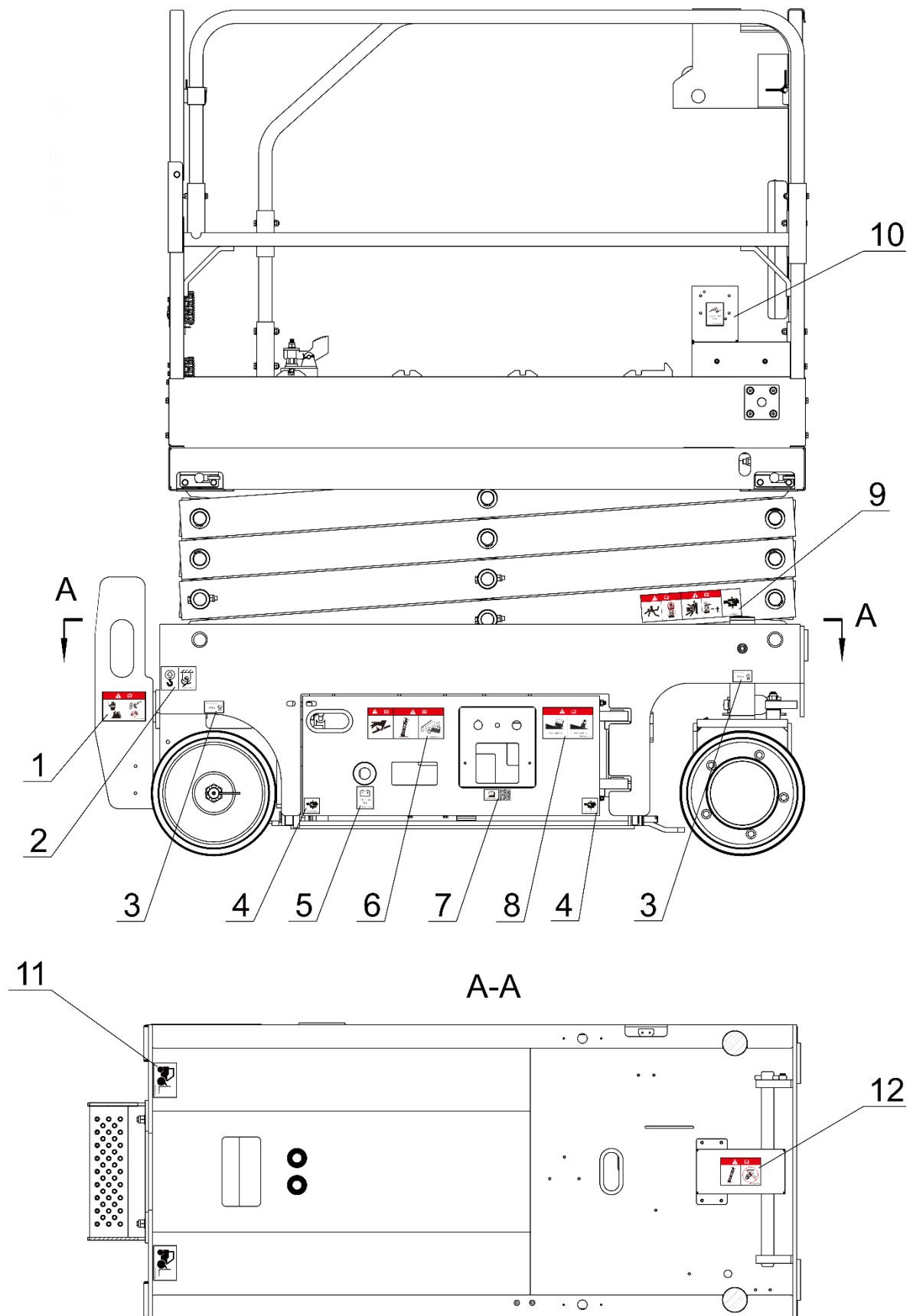

Figure 3-1 Decal position1 (ZS0607E Series)

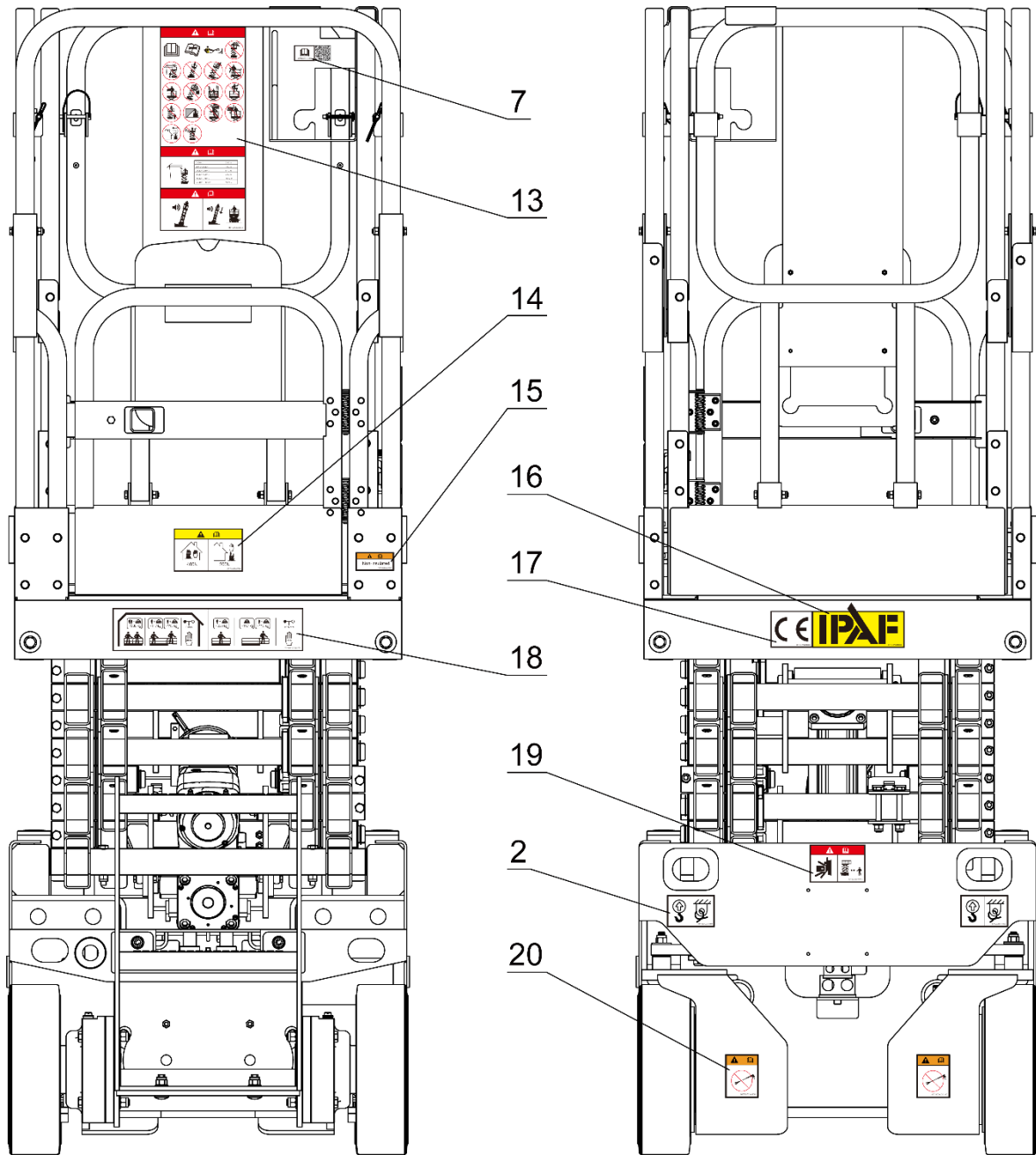

Figure 3-2 Decal position2 (ZS0607E Series)



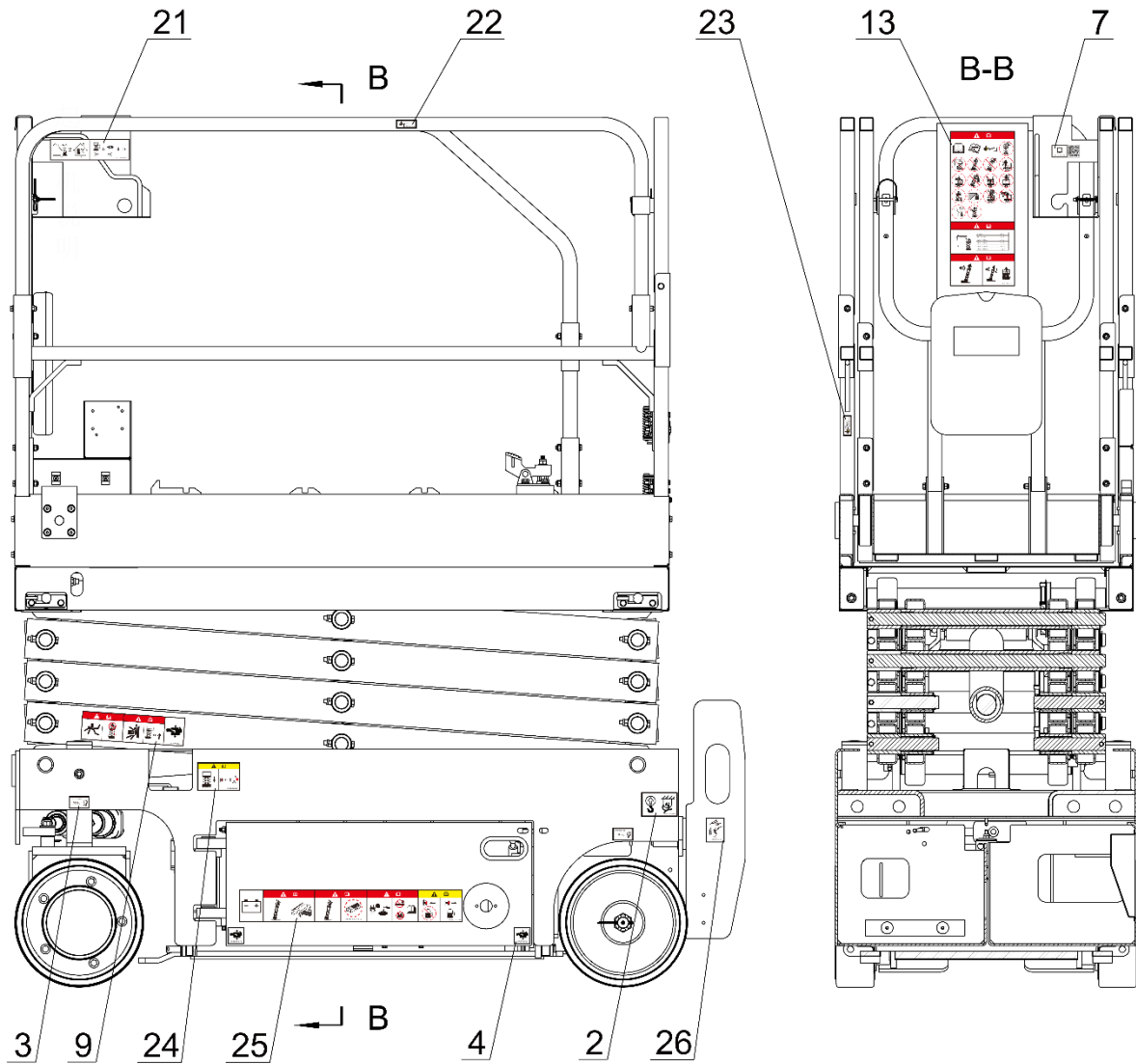
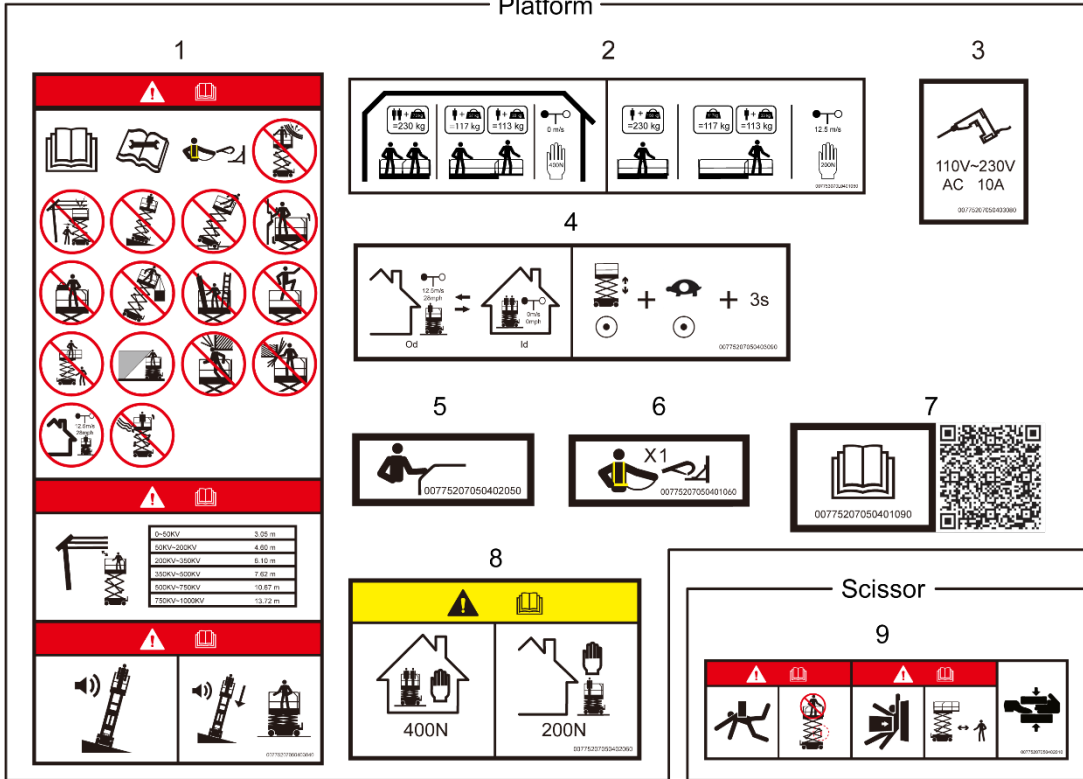

Figure 3-3 Decal position3 (ZS0607E Series)

## ZS0607E Series

### Platform



### Chassis

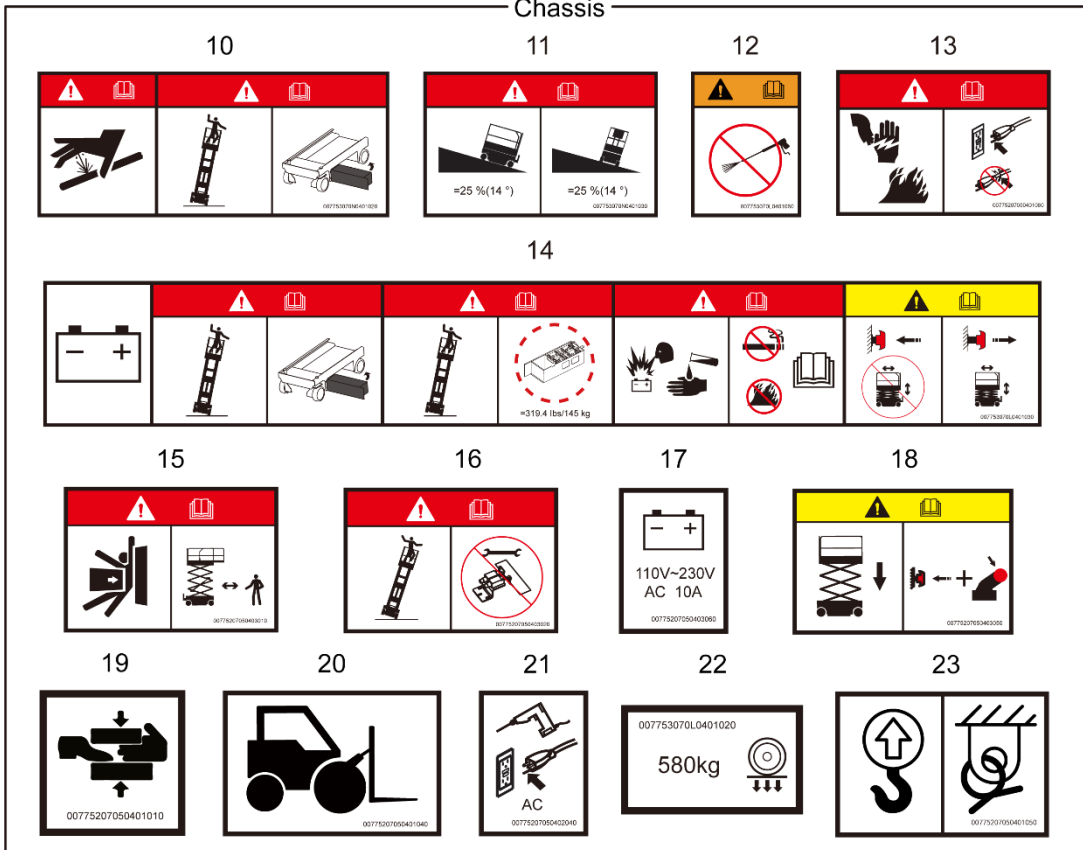

Figure 3-4 Decal 1

Table 3-2 Decal 2 (ZS0407E Series)

NO.	Code	Item	Qty
1	00775207050401080	Label- Electrocutation Hazard	1
2	00775207050402030	Label- Wheel Load, 390kg/860 lbs	4
3	00775207050401010	Label- Anti-pinch	4
4	00775207050402020	Label- 4m Left	1
5	00775207050402010	Label- Crushing and Safety Arm	2
6	00775207050403080	Label- Platform Power Rated Voltage	1
7	00775207050403020	Danger- Tip-over Hazard	1
8	00775207050403050	Label- Emergency Lowering	1
9	00775207050401070	Instruction- Main Power Switch Operation	1
10	00775207050403010	Danger- Crushing Hazard	1
11	00775207050403040	Label- Safety Rules and Tipping (Outdoor)	1
12	00775207050402060	Label- Max Manual Force (Outdoor)	1
13	00775207050403070	Label- Capacity, 240kg/530 lbs (Outdoor)	1
14	00775207050401050	Label- Lifting and tying	4
15	00775207050401040	Label- Forklift Hole	2
16	00775207050401090	Label- Read the Instructions Carefully	2
17	00775207050403030	Label- CE	
18	00775207050401030	Label- IPAF	
19	00775207050402090	Label- non-insulated	1
20	00775207050403060	Label- Charger Power Supply	
21	00775207050402040	Label- AC Power to Platform	
22	00775207050403090	Label- Indoor and Outdoor Mode Switching	1
23	00775207050402050	Label- Handrail position	3
24	00775207050401060	Label- Lanyard Anchorage Point	4

MACHINE INSPECTION

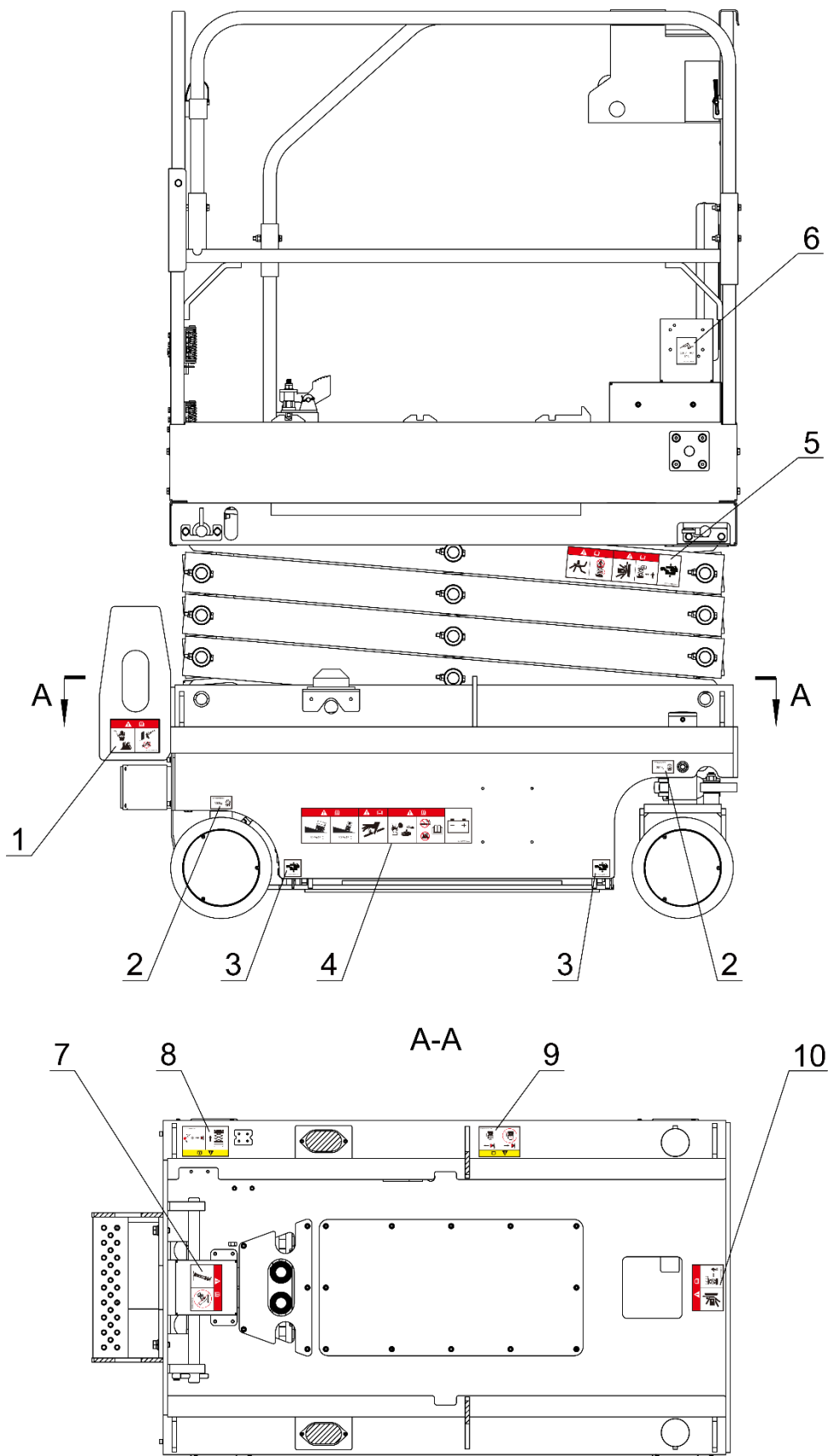

Figure 3-5 Decal position1 (ZS0407E Series)

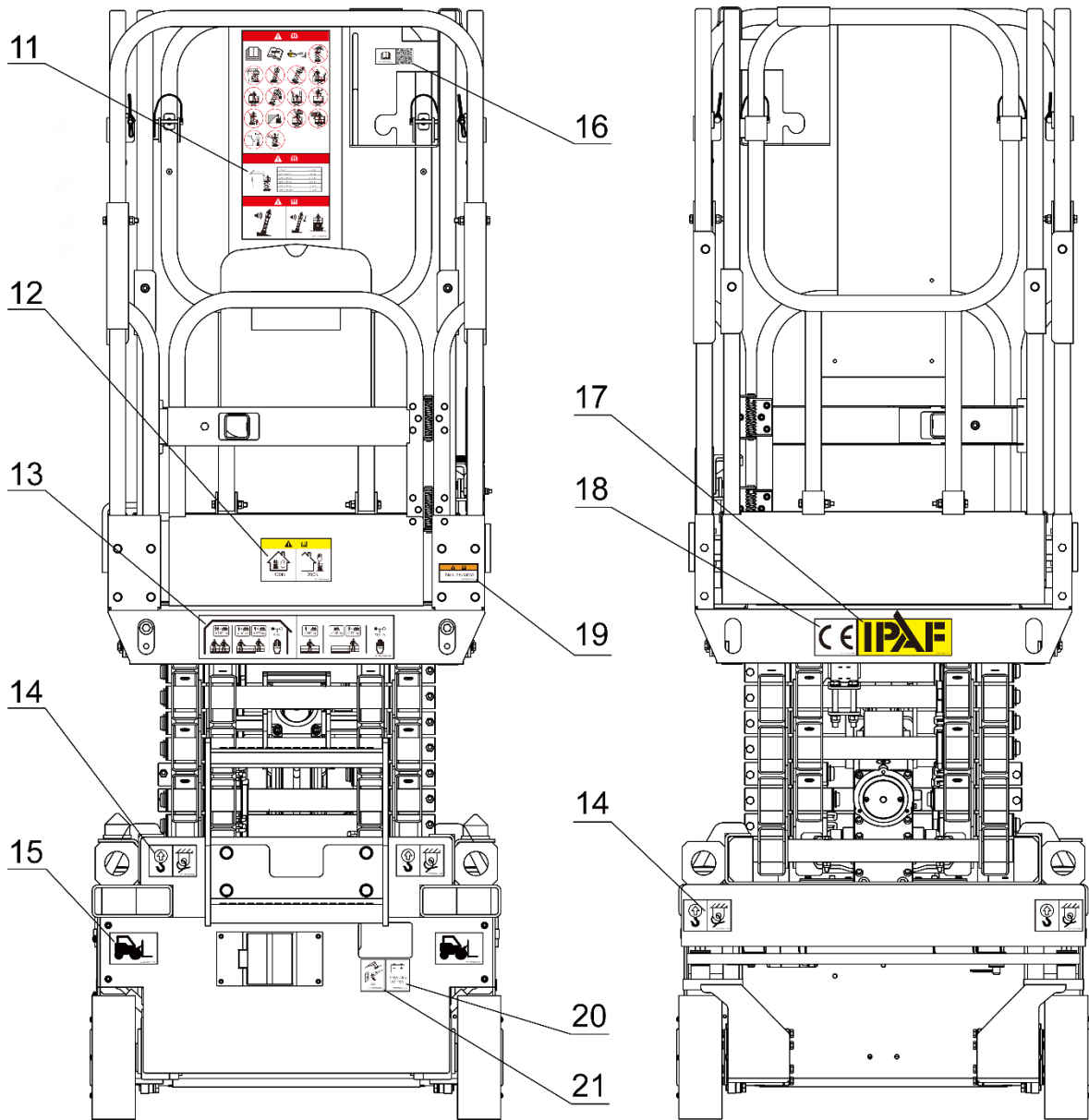

Figure 3-6 Decal position2 (ZS0407E Series)

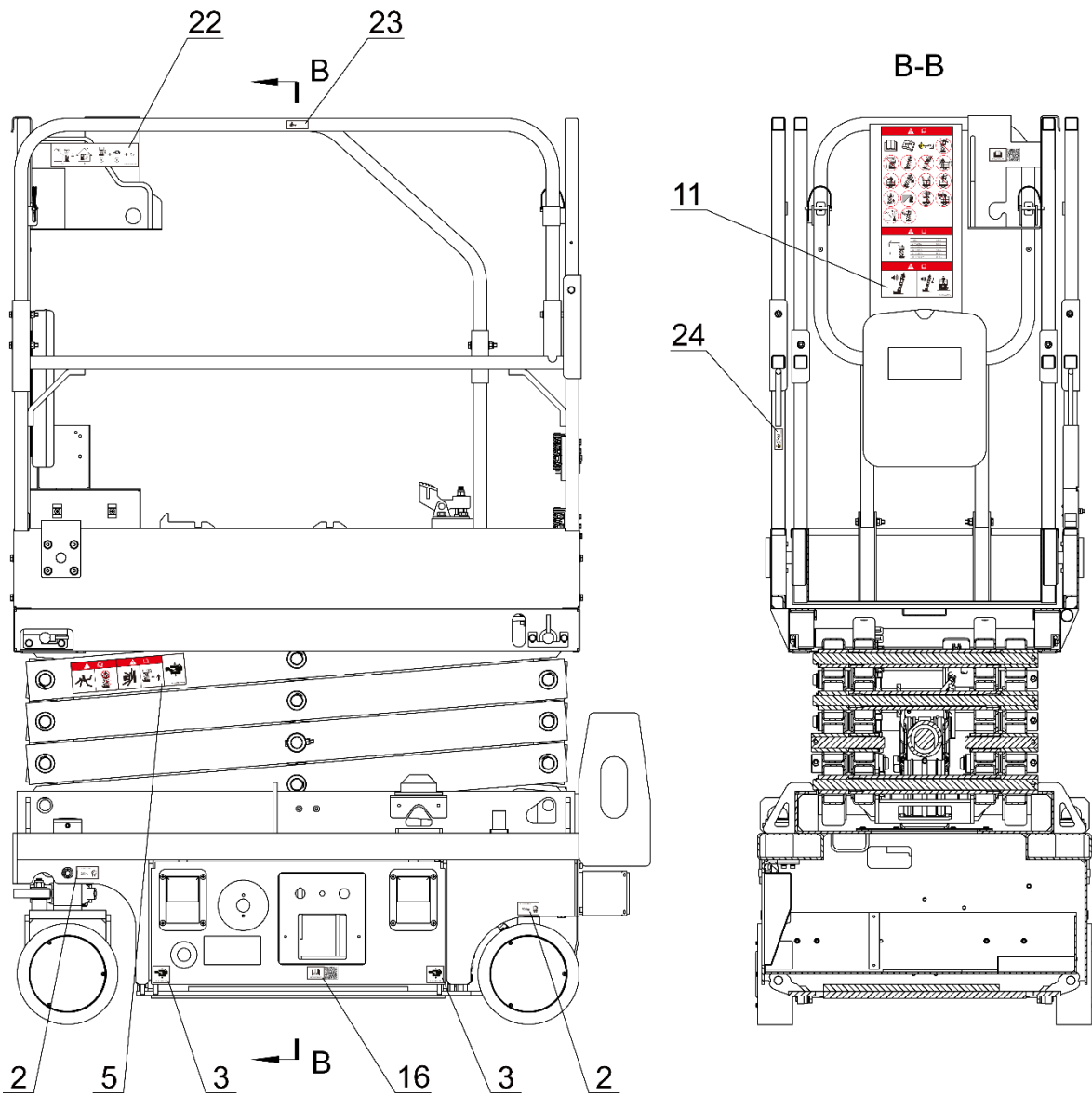
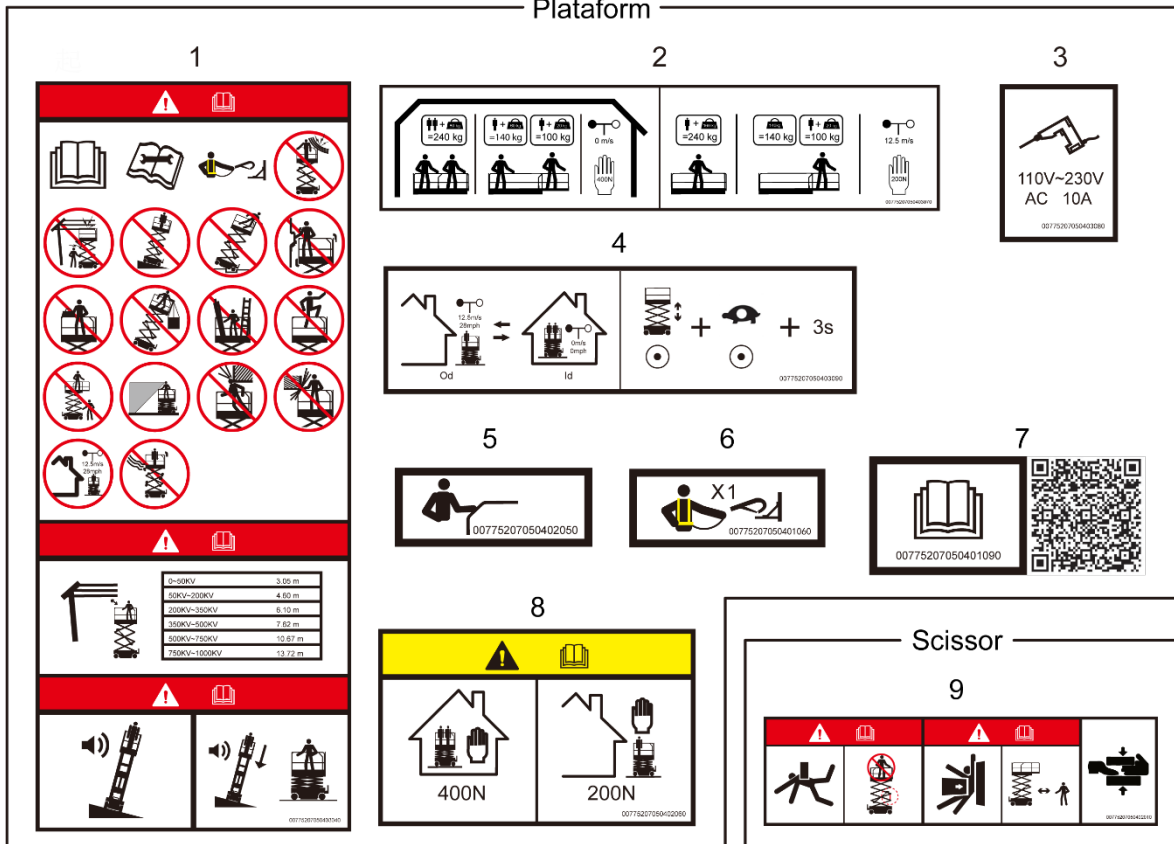

Figure 3-7 Decal position3 (ZS0407E Series)

ZS0407E Series

Platform



Chassis

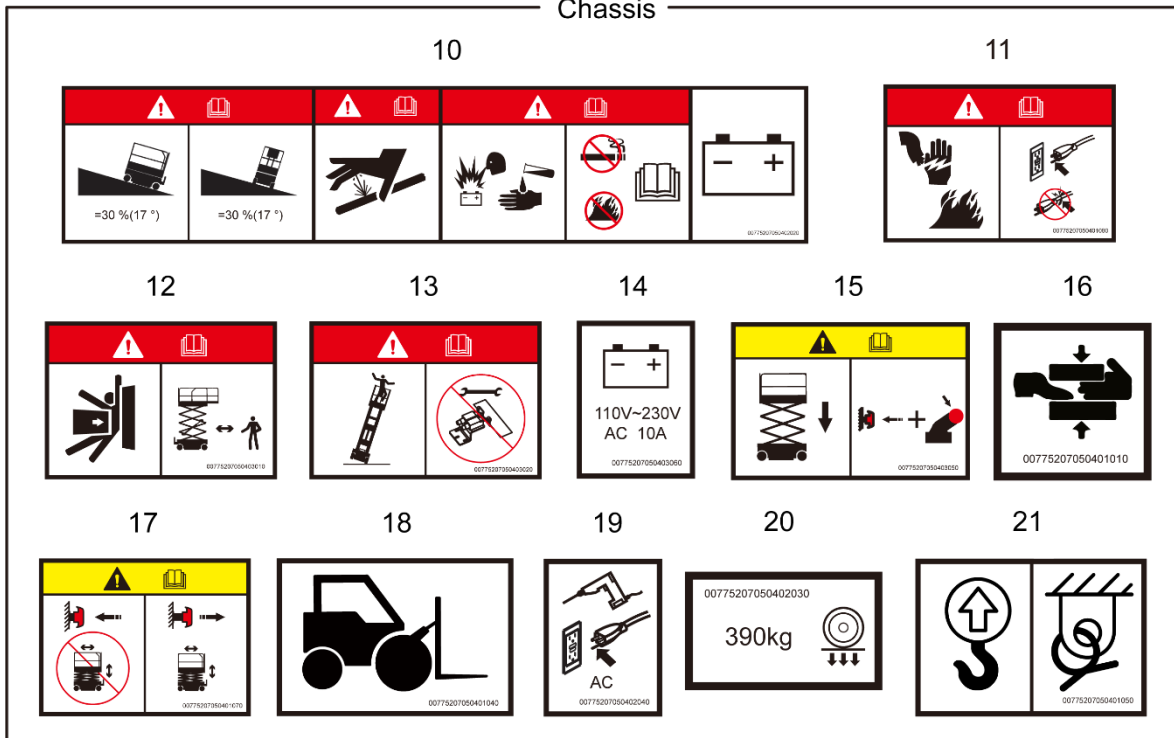

Figure 3-8 Decal 2

起重机说明

上车操作



## SECTION 4 OPERATION INSTRUCTION

### 14. 4.1 General

#### **⚠ DANGER**

**An operator must not operate the machine, only if he has learned and practiced the principles of safe machine operation contained in this operational manual.**

- k) Avoid hazardous situations.
- l) Perform a pre-operation inspection at all times.
- m) Implement functional test before operating the machine at all times.
- n) Inspect job site.
- o) Only use the machine as it was intended.

Fundamentals:

The Operating Instructions section provides instructions for each aspect of machine operation. It is the operator's responsibility to follow all the safety rules and instructions in the operator's safety and responsibilities manuals.

Using the machine for anything other than lifting personnel, along with their tools and materials, to an aerial work site is unsafe and dangerous.

Only trained and authorized personnel should be permitted to operate a machine. If more than one operator is expected to use a machine at different times in the same work shift, they must all be qualified operators and are all expected to follow all safety rules and instructions in the operator's, safety and responsibilities manuals. That means every new operator should perform a pre-operation inspection, function tests, and a workplace inspection before using the machine.

### 15. 4.2 Machine Operation

#### 4.2.1 Turn on/off main power switch

- p) Push in the red Power Switch to the off position at the battery box side to shut off machine power.
- q) Pull out the red Power Switch to on position to operate the machine.
- r) If the machine is out of service for a long time or in maintenance, turn off the Power Switch.



### 4.2.2 Emergency stop

- s) Push in the red Emergency Stop button to the off position at the electronic controls or the platform controls to stop all functions.
- t) Repair any function that operates when Power Switch and red Emergency Stop button are pushed in.

### 4.2.3 Emergency lowering

Cut off power supply, the press the emergency lowering knob to lower the platform.

### 4.2.4 Operation after usage

- u) Select a safe parking location-firm level surface, clear of obstruction and traffic.
- v) Lower the platform.
- w) Turn the key switch to the off position and remove the key to secure from unauthorized use.
- x) Charger the batteries.

## 4.3 Operation from Ground

### **CAUTION**

**Maintain safe distances between the operator, the machine and fixed objects.**

**Notice the drive direction when using the controller.**

### 4.3.1 Start electronic operation function

- y) Be sure the battery pack is connected before operating the machine.
- z) Turn the key switch to electronic control.
- aa) Pull out both ground and platform red Emergency Stop buttons to the on position.

### 4.3.2 Adjust platform position

Press and hold both lifting enable button and platform up/down button on control panel to adjust platform position.

Drive and steer functions are not available from the electronic controls.

## 4.4 Operation from Platform

### 4.4.1 Start platform operation function

- bb) Be sure the battery pack is connected before operating the machine.
- cc) Turn the key switch to platform control.
- dd) Pull out both ground and platform red Emergency Stop buttons to the on position.

#### 4.4.2 Adjust platform position

ee) Press the lift function enable button.



On the LCD screen, a circle below the lift function symbol will turn on.

If the control handle is not moved within seven seconds of pushing the lift button, the circle below the lift function symbol will turn off and lift function will not operate. Press the lift function button again.

ff) Press and hold function enable switch on handle while the lifting function indicator is on.

gg) Move the control handle according to markings on the control panel.

#### 4.4.3 Steering

hh) Press the drive function button.

On the LCD screen, a circle below the drive function symbol will turn on.

If the control handle is not moved within seven seconds of pushing the drive function button, the circle below the drive function symbol will turn off and drive function will not operate.

ii) Press and hold function enable switch on handle while the drive function indicator is on.

jj) Press and hold steering thumb button on the top of handle for steering according to the symbols on control panel.



#### 4.4.4 Drive

kk) Press the drive function button. On the LCD screen, a circle below the drive function symbol will turn on.

If the control handle is not moved within seven seconds of pushing the drive function button, the circle below the drive function symbol will turn off and drive function will not operate.

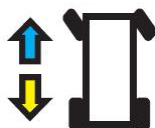

ll) Press and hold function enable switch on handle while the drive function indicator is on.

mm) Increase speed: slowly move the control handle off center.

- nn) Decrease speed: slowly move the control handle toward center.
- oo) Stop: return the control handle to center or release the function enable switch.
- pp) Use the color-coded direction arrows on the platform controls and on the platform to identify the direction the machine will travel.
- qq) Machine travel speed is restricted when the platform is raised.
- rr) Battery condition will affect machine performance. Machine drive speed and function speed will drop when the battery level indicator is flashing.

### 4.4.5 Drive speed selection

Select the desired drive speed by control handle, usually, the machine is in the normal drive speed. Press the slow drive speed mode button, the circle below the button will turn on, slow drive speed mode is activated, the drive speed will restricted even if the control handle moves to the max speed position.



### 4.4.6 Load weight display

- ss) Only press the left turn button at the top of the control handle to enable the load weight display function;
- tt) Two digits are displayed. Taking 2.4 as an example, the actual weighing load is  $2.4 \times 100 = 240\text{kg}$ .
- uu) Release the left turn button, and the display will return to normal status.



### 4.4.7 Platform AC power

Pull out the power plug on the left side of climbing ladder when using the platform AC power (if equipped), connect it to ground power socket. AC power socket on platform could provide AC power.

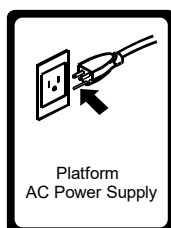

**4.4.8 Indoor and outdoor working mode selection**

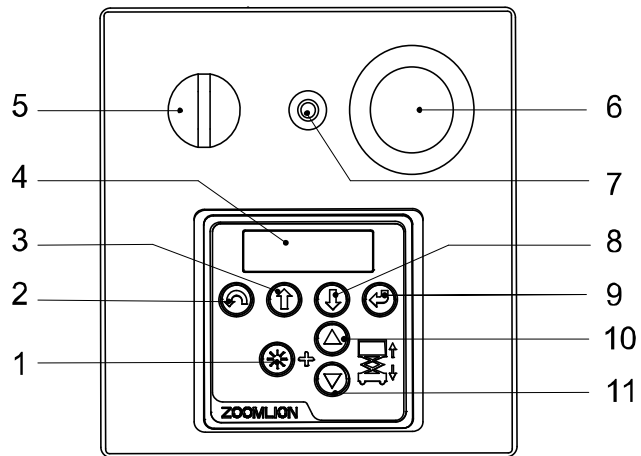

**Figure 4-1 Electronic control Panel**

**Table 4-1 Electronic control panel instruction**

No.	Item	No.	Item
1	Lifting enable button	7	10A breaker
2	Menu escape button	8	Menu down button
3	Menu up button	9	Menu enter button
4	LCD diagnostic readout	10	Platform up button
5	Key switch	11	Platform down button
6	Emergency stop switch		

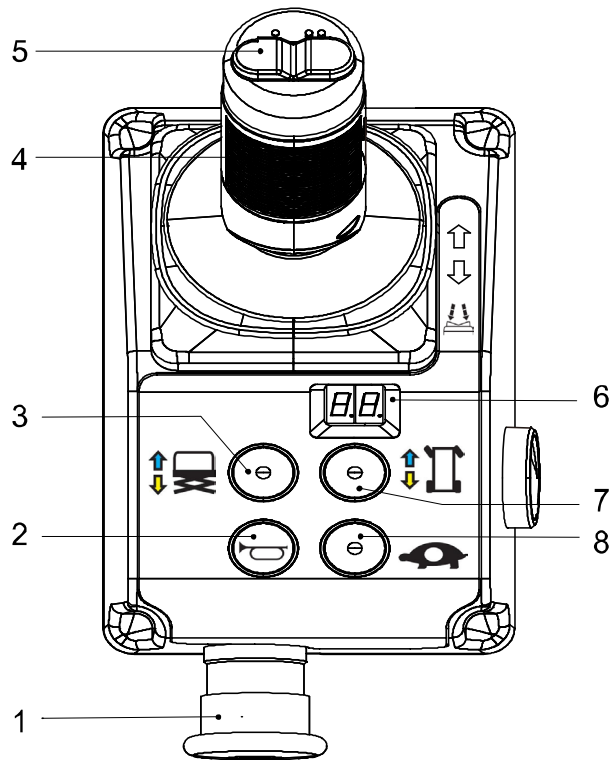

Figure 4-2 Platform control panel

Table 4-2 Platform control panel instruction

No.	Item	No.	Item
1	Emergency stop switch	5	Steering thumb button
2	Horn button	6	LED Readout
3	Lift function button	7	Drive function button
4	Control handle	8	Drive speed button

vv) Push the emergency stop switch to OFF position, and turn the key switch to Ground position. Press the Input button on menu and pull out emergency stop button to ON position to enter the Menu interface.

ww) Press Down button, then press Enter button when the display shows as below.

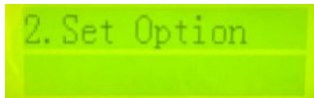

xx) Continuously press Down button until the below interface shows up, then press the Enter button.

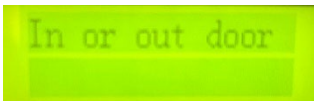

yy) If the display shows as below, indicating indoor and outdoor functions disabled, only indoor working mode is allowed at this time, as shown in(h).

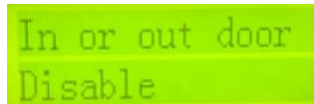

zz) If the display shows as below, indicating indoor and outdoor functions enabled, then press Enter button, at this time, the default is outdoor working mode, as shown in(g).

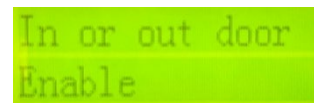

aaa) Restart the machine, turn the key switch to Platform position, operate the machine through the platform control panel.

bbb) If the below two interfaces automatically switch back and forth, the machine is in outdoor working mode at this time.



ccc) Press Lifting function button and Driving speed button at the same time, when the below two interfaces switch back and forth, release the buttons, at this time, the machine is in indoor working mode.

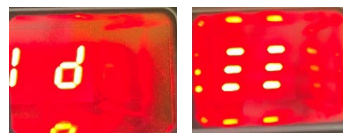

## 16. 4.5 Operation on Slope

### 4.5.1 Driving on a slope

**⚠ DANGER**

ddd) Determine the longitudinal and lateral ratings and slope of the slope under machine retract condition.

**Table 4-3 Longitudinal rating**

Maximum longitudinal rating in the stowed state			
	ZS0407E Series	30%	17°
	ZS0607E Series	25%	14°

**Table 4-4 Lateral rating**

Maximum lateral rating in the stowed state			
	ZS0407E Series	30%	17°
	ZS0607E Series	25%	14°

- b) Slope rating is limited by ground conditions and traction. Press the drive speed button to the fast drive speed mode.
- c) Measure the slope with a digital inclinometer OR use the following procedure. You will need: carpenter's rule, straight block (minimum length 1m/ 3ft 3in), tape measure.
  - 1) Lay the piece of wood on the slope.
  - 2) At the downhill end, lay the level on the top of edge of the piece of wood and lift the end until the piece of wood is level.
  - 3) While holding the piece of wood level, measure the vertical distance from the bottom of the piece of wood to the ground. Divide the tape measure distance (rise) by the length of the piece of wood (run) and multiply by 100.

Example:

Block = 3.6m /12ft (144in),

Stroke=3.6m /12ft,

Rise = 0.3m /12in,

Grade  $0.3m /12in \div 3.6m /144in = 0.083 \times 100 = 8.3\%$ .



If the slope exceeds the maximum slope or side slope rating, then the machine must be winched or transported up or down the slope. See Transport and Lifting section.

### 4.5.2 Operating on a slope

**⚠ DANGER**



Determine the rating of the chassis working Angle when the machine is working longitudinally and laterally on the slope.

Table 4-5 Maximum chassis working Angle

Model	Longitudinal rating	Lateral rating
ZS0407E Series	3°	1.5°
ZS0607E Series	3°	1.5°

If the slope exceeds the chassis working Angle rating, tilt alarm will sound, then the platform must be lowered carefully. Move the machine to a firm, level surface before lifting.

## 17. 4.6 Traction

a) Notice (ZS0407E/ZS0607E Series):

It is not recommended that this machine be towed, except in the event of an emergency such as a machine malfunction or a total machine power failure.

b) Warning:

- 1) If the machine has any inclination, the wheel must be fully blocked before manually releasing the brake, otherwise it may cause injury or even death.
- 2) Runaway Hazard. The equipment does not have traction brakes and the towing vehicle must be able to control the equipment at all times. Do not conduct traction on the highway. Failure to do so could result in serious injury.
- 3) Maximum traction speed should not exceed 3.2km/h (2 mile/h), and the traction spacing should not exceed 18m /60 ft. Maximum traction slope should not exceed 25%.

c) The device provides two ways to release the brakes: the electronically released brake and the mechanical way:

1) Electronically released brake:

- ① Pull out device main power switch, platform emergency stop button and ground emergency stop button.
- ② Press and hold ECU Menu Entry Button.

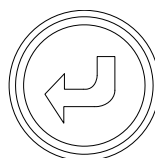

- ③ Turn the key switch to electronic control.
- ④ Until the following interface appears on the LCD reading device:

## 1. Set Speed

- ⑤ Scroll to the following screen by pressing the Menu Down Button:

## 4. Machine Mode

- ⑥ Press Menu Entry Button to display following interface:

## Break Release

- ⑦ Long press Menu Entry Button to display the following interface, and the buzzer will alarm, indicating that the brake has been released.

## Break Is Released

- ⑧ After the equipment is towed, the key switch is turned off and the brake is restored.

### 2) Mechanical brake release (ZS0607E) :

- ① Press device main power switch, platform emergency stop button and ground emergency stop button.
- ② Remove the two rear cover bolts, and the brake cover bolts are also the release bolts for the brakes. Rear cover bolts size M5×0.8×20mm, see the following icon 1.
- ③ Remove brake cover, see the following icon 2.
- ④ Insert the rear cover bolt 1 into the two manual release holes 3 of the brake housing.

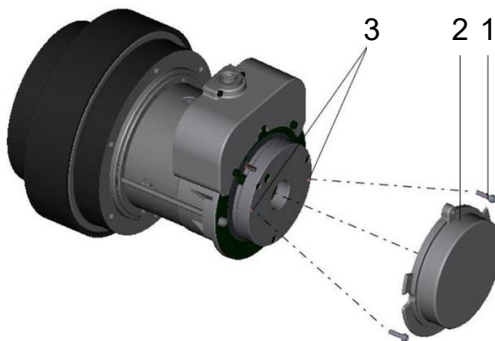
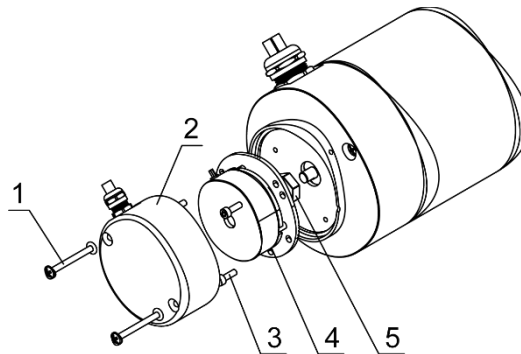

Figure 4-3 Brake diagram

- ⑤ Tighten the bolt to release the brake.
  - ⑥ Repeat this process for the other wheel drive.
- 3) Mechanical brake release (ZS0407E) :
- ① Press device main power switch, platform emergency stop button and ground emergency stop button.
  - ② Remove the two mounting screws of the rear cover. The size of the screw is M4×40mm, see the following icon 1.
  - ③ Remove the rear cover, see the following icon 2.
  - ④ Remove the three mounting bolts of the brake device. The size of the screw is M4×12mm, see the following icon 3.
  - ⑤ Remove the brake device, see the following icon 4.
  - ⑥ Use a 2mm Allen key to remove the screws in the hexagonal sleeve to release the brake.
  - ⑦ Repeat this process for the other wheel drive.



The brake must be restored after the machine has been towed or pushed to the maintenance position.

## 18. 4.7 Operation Code

### 4.7.1 Operation indicator code

If the platform controls LED or electronic controls LCD diagnostic readout displays an operational indicator code such as LL, the fault condition must be repaired or removed before resuming machine operation. Push in and pull out the red Emergency Stop button to reset the system.

- a) LED Readout.



- b) LCD Readout.

**LL: MACHINE TILTED**

- c) Operation Indicator Code:
- 1) LL Off-Level.
  - 2) OL Overload.
  - 3) CH Chassis Mode Operation.
  - 4) 18 Pothole Guard Fault.
  - 5) 37 Battery Exhausted.

Refer to Zoomlion Maintenance manual for further information. A code and a description of a code can also be viewed at the electronic controls LCD display.

### 4.7.2 Platform overload

If the platform controller LED diagnostic readout displays OL, and the electronic controller LCD diagnostic readout displays OL as well, it indicates platform overloaded, except for the descent function, other functions will stop. Alarm will sound.



**OL**



**OL: PLATFORM OVERLOAD**

- a) Press the red Emergency Stop button to off position.
- b) Remove load from platform.
- c) Pull out the Red Emergency Button to the on position to operate the machine.
- d) The reading device shows normal.

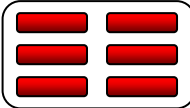
### 4.7.3 Battery level indicator

Use the LED diagnostic readout to determine the lead acid or lithium-ion battery level. When Low Charge appears on the platform controls LED display, the machine must be taken out of service and charged, otherwise all machine functions will be disabled.

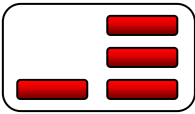
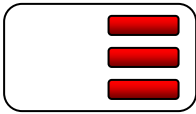
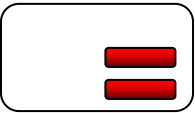
	
Battery Level:90-100%	Battery Level:70%

	
Battery Level:50%	Battery Level:30%
	
Battery Level:20%	Battery Level:10%

## 19. 4.8 Safety Arm and Guard Operation

### 4.8.1 How to use the safety arm

- Attempt to raise the platform to approximately 2.4m/7ft 10in .
- Rotate the safety arm away from the machine and let it hang down.
- Lower the platform until the safety arm rests securely on the link. Keep clear of the safety arm when lowering the platform.

### 4.8.2 How to fold guard

The platform railing system consists of three fold down rail sections for the extension deck and three sections for the main deck. All six sections are held in place by four wire lock pins.

- Fully lower the platform and retract the platform extension.
- Remove the platform controls.
- From inside the platform, remove the two extension deck lock pins.
- Fold the front rail components. Keep hands free of pinch points.
- Replace the two moved pins back into each side rail bracket.
- Fold the rail components of each side. Keep hands free of pinch points.
- At the rear of the main deck, remove the two main deck lock pins.
- Carefully open the gate and exit the platform.
- Fold down the rear gate and entry side rails as one unit. Keep hands free of pinch points.
- Fold down the left and right side rails. Keep hands free of pinch points.
- Replace the two moved pins back into each side rail bracket.

### 4.8.3 How to raise guard

Follow the fold down instructions but in reverse order, ensuring all lock pins are in place and installed properly.

#### 4.8.4 Operation after usage

- a) Select a safe parking location-firm level surface, clear of obstruction and traffic.
- b) Lower the platform.
- c) Turn the key switch to the off position and remove the key to secure from unauthorized use.
- d) Charge the batteries.

## 20. 4.9 Battery and Charger Operation

### **CAUTION**

#### Battery and Charger Instruction.

##### 4.9.1 Observe and obey

- a) Do not use an external charger or booster battery.
- b) Charge the battery in a well-ventilated area.
- c) Use proper AC input voltage for charging as indicated on the charger.
- d) Use only a ZOOMLION authorized battery and charger.

##### 4.9.2 Charging the battery

- a) Be sure the batteries are connected before charging the batteries.
- b) Open the battery compartment. The compartment should remain open for the entire charging cycle.

##### 4.9.3 Maintenance free battery

- a) Connect the battery charger to a grounded AC circuit.
- b) The charger will indicate when the battery is fully charged.

##### 4.9.4 Standard battery

- a) Remove the battery vent caps and check the battery acid level. If necessary, add only enough distilled water to cover the plates. Do not add excessive distilled water before the charging process.
- b) Replace the battery vent caps.
- c) Connect the battery charger to a grounded AC circuit.
- d) The charger will indicate when the battery is fully charged.
- e) Check the battery acid level when the charging cycle is complete. Replenish with distilled water to the bottom of the fill tube. Do not overfill.

##### 4.9.5 Dry battery filling and charging instructions

- a) Remove the battery vent caps and permanently remove the plastic seal from the battery vent openings.

- b) Fill each cell with battery acid (electrolyte) until the level is sufficient to cover the plates.
- c) Do not fill to maximum level until the battery charge cycle is complete. Overfilling can cause the battery acid to overflow during charging. Neutralize battery acid spills with baking soda and water.
- d) Install the battery vent caps.
- e) To Charge Battery.
- f) Check the battery acid level when the charging cycle is complete. Replenish with distilled water to the bottom of the fill tube. Do not overfill.

## 21. 4.10 Lithium-ion Battery and Charger Operation

### **▲ CAUTION**

#### Lithium-ion Battery and Charger Instruction

##### 4.10.1 Observe and obey

- a) Lithium-ion battery fast charge charger power reaches 1500W/2 hp, charging AC input current is 8A. Please select the power outlet with sufficient load to charge the device, the regular ordinary (10A) can only charge one device.
- b) Do not over charge or over discharge the lithium-ion battery.
- c) If there is heat, deformation, liquid leakage, odor or smoke when charging, stop using the lithium-ion battery and place the battery in an open place away from the crowd.
- d) The battery is only suitable for the matching equipment, and the battery should not be used in other occasions.
- e) It is forbidden to use the wire to directly short the battery output port.
- f) Do not use or store this product in environments such as corrosive, explosive, high temperature (heating, near fire or sun exposure).
- g) When charging, please use the special charger that comes with the device, and avoid charging in direct sunlight. Do not let children touch the charger in use.
- h) If the battery system is not used for a long time, it should be placed in a cool and dry environment (temperature below 30°C/86°F, humidity less than 90%) and charged at least once every three months.
- i) When the battery voltage is too low, it should be charged in time, otherwise the battery will be over-discharged and the machine will not move.
- j) Do not apply external force to the battery or drop it from high altitude.
- k) Keep the battery away from heat.
- l) Do not use an external charger or booster battery.

- m) Charge the battery in a well-ventilated area.
- n) Use proper AC input voltage for charging as indicated on the charger.
- o) Use only a ZOOMLION authorized charger.
- p) It is strictly forbidden for non-professionals to disassemble and modify the battery system. For repairs, please contact our after-sales personnel.

#### 4.10.2 Charging lithium-ion battery

- a) Connect the battery charger to a grounded AC circuit.
- b) Keep the battery tray open during battery charging, but avoid rain.
- c) The charger will indicate when the battery is fully charged.

## 22. 4.11 Transport and Lift

### 4.11.1 Observe and obey

- a) ZOOMLION provides this securement information as a recommendation. The driver is solely responsible for ensuring that the machine is properly secured and the correct trailer is selected pursuant to CHINA Department of Transportation regulations, other localized regulations, and their company policy.
- b) ZOOMLION customers needing to containerize any lift or ZOOMLION product should source a qualified freight forwarder with expertise in preparing, loading and securing construction and lifting equipment for international shipment.
- c) Only qualified aerial lift operators should move the machine on or off the truck.
- d) The transport vehicle must be parked on a level surface.
- e) The transport vehicle must be secured to prevent rolling while the machine is being loaded.
- f) Be sure the vehicle capacity, loading surfaces and chains or straps are sufficient to withstand the machine weight. ZOOMLION lifts are very heavy relative to their size. See the serial label for the machine weight.
- g) Be sure the machine is on a level surface or secured before releasing the brake.
- h) Do not allow the rails to fall when the snap pins are removed. Maintain a firm grasp on the rails when the rails are lowered.
- i) Do not drive the machine on a slope that exceeds the uphill, downhill or side slope rating. See Driving on a Slope in the Operating Instructions section.
- j) If the slope of the transport vehicle bed exceeds the maximum slope rating, the machine must be loaded and unloaded using a winch as described in the brake release operation.

### 4.11.2 Transport



## a) Brake Release Operation:

- 1) Chock the wheels to prevent the machine from rolling.



- 2) Be sure the winch line is properly secured to the drive chassis tie points and the path is clear of all obstructions.
  - 3) For the brake release of ZS0407E/ZS0607E series models, please refer to 4.6.
- b) After loaded:
- 1) Chock the wheels to prevent the machine from rolling.
  - 2) Push the red Emergency Stop button at both ground and platform controls to the off position.
- c) Towing the machine is not recommended. If the machine must be towed, do not exceed 3.2 km/h (2mile/h).
- d) Securing to Truck or Trailer for Transit:
- 1) Always use the extension deck lock when the machine is transported. Turn the key switch to the off position and remove the key before transporting.
  - 2) Inspect the entire machine for loose or unsecured items. Use chains or straps of ample load capacity.
  - 3) Use a minimum of 2 chains or straps. Adjust the rigging to prevent damage to the chains.

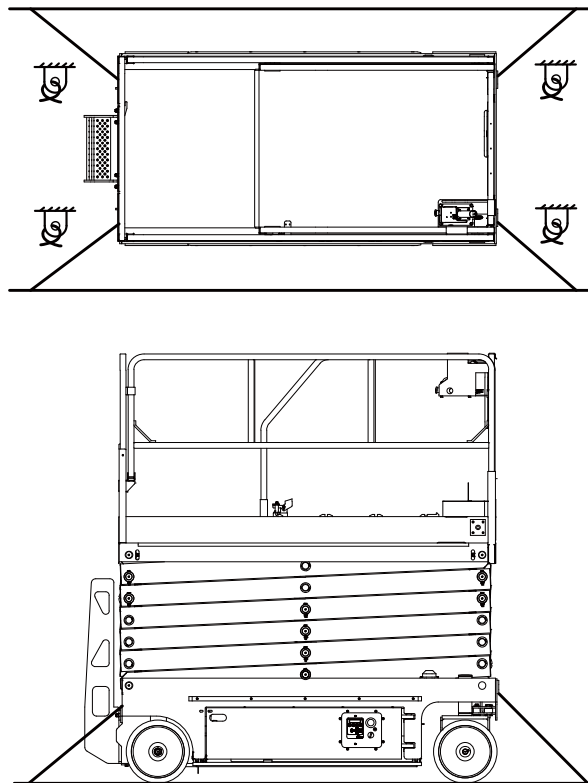
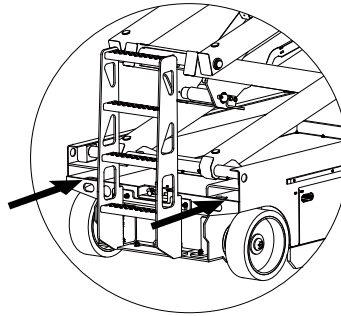

**Figure 4-4 Tie down points**

### 4.11.3 Lift

#### **⚠WARNING**

- a) Observe and Obey:
  - 1) Only qualified riggers should rig and lift the machine.
  - 2) Only qualified forklift operators should lift the machine with a forklift.
  - 3) Be sure the crane capacity, loading surfaces and straps or lines are sufficient to withstand the machine weight. See the serial label for the machine weight.
- b) Lifting the machine with a Forklift:
  - 1) Be sure the extension deck, controls and component trays are secured. Remove all loosen parts.
  - 2) The platform must remain lowered during all loading and transport procedures.
  - 3) Use the forklift pockets located on both sides of the ladder. See Figure 4-3.

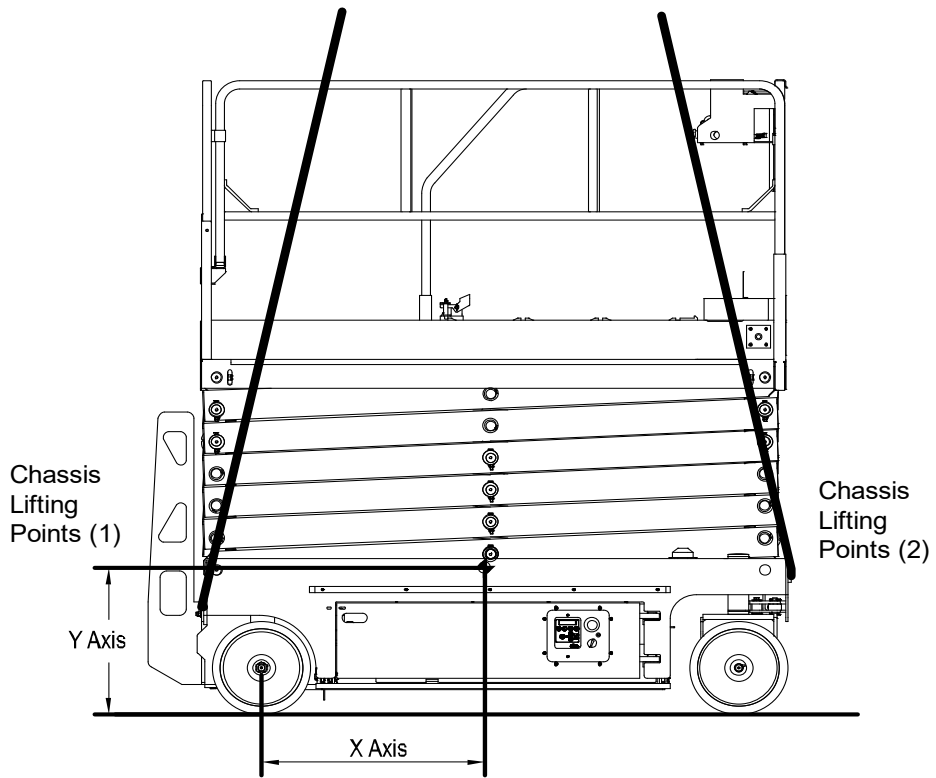

**Figure 4-5 Forklift pockets**

- 4) Align the forklift fork with the position of the forklift pockets and drive forward until the fork is fully inserted.
  - 5) Raise the machine 0.4m /1ft 4in and then tilt the forks back slightly to keep the machine secure.
  - 6) Be sure the machine is level when lowering the forks.
- c) Lifting Instruction:
- 1) Fully lowering the platform. Be sure the extension deck, controls and component trays are secured. Remove all loose items on the machine.
  - 2) Use Table 4-6 and Figure 4-6 to determine the center of gravity of the machine.
  - 3) Attach the rigging only to the designated lifting points on the machine. There are two 2.5cm/1 in holes on the front of the machine, and two holes on the rear of the machine for lifting.
  - 4) Adjust the rigging to prevent damage to the machine and to keep the machine level.

**Table 4-6 Center of gravity**

Model	X Axis	Y Axis
<b>ZS0407E Series</b>	49.8 cm/1ft 8in	42.1 cm/1ft 5in
<b>ZS0607E Series</b>	69.5 cm/2ft 3in	54 cm/1ft 9in



**Figure 4-6 Center of gravity**

# **ZOOMLION**

**Operation and Safety Manual**

**Section 5 Maintenance**





## SECTION 5 MAINTENANCE

### 23. 5.1 General



Observe and Obey:

- d) Only routine maintenance items specified in this manual shall be performed by the operator.
- e) Scheduled maintenance inspections shall be performed by qualified service technicians, according to the manufacturer's specifications and the requirements listed in the responsibility's manual.
- f) Disposal of materials should be according to the regulations of government and relevant environmental protection administration.
- g) Use only ZOOMLION approved replacement parts. ZOOMLION assumes no responsibility for hazards occurred to equipment and personnel caused by the use of unauthorized parts.

#### 5.1.1 Maintenance symbols legend

The following symbols have been used in this manual to help communicate the intent of the instructions. When one or more of the symbols appear at the beginning of a maintenance procedure, it conveys the meaning below.



Indicates that tools will be required to perform this procedure.



Indicates that new parts will be required to perform this procedure.

#### 5.1.2 Pre-start inspection

- a) Be sure operator's, safety, and responsibilities manuals are complete, legible, and in the storage, container located on the machine.
- b) Be sure all decals are in place and legible.
- c) Check for hydraulic oil leaks and proper oil level. Add oil if needed. See Maintenance section.
- d) Check for battery fluid leaks and proper fluid level. Add distilled water if needed after battery charged. Check the following components or areas for damage, improperly installed, or missing parts and unauthorized modifications:
  - 1) Electrical components, wiring, and electrical cables.

- 2) Lifting and steering liner actuator.
- 3) Drive motor/motor.
- 4) Wear pads.
- 5) Tires and wheels.
- 6) Limit switches and horn.
- 7) Alarm and indicator (if equipped).
- 8) Nuts, bolts and other fasteners.
- 9) Brake release unit.

### 5.1.3 Maintenance hazard

- h) Shut off power to all controls and ensure that all moving parts are secured from inadvertent motion prior to performing any adjustments or repairs.
- i) Never work under an elevated platform until it has been fully lowered to stowed position, if possible, or otherwise supported and restrained from movement with appropriate safety props, blocking, or overhead supports.
- j) DO NOT attempt to repair or steer liner actuator while the machine is powered on.
- k) Maintain the scissor arm pipelines, components, and liner actuator with safety arm supported and in full contact.
- l) Stop operating the platform when the safety arm is fully raised and contacted.



### 5.1.4 Body injury hazard

When the system is powered off or fails to operate, press the emergency lowering knob. If the descending speed is abnormally accelerated, please release the emergency lowering knob immediately and stop the emergency descending action. Abnormally rapid emergency descent may result in physical injury to personnel on the platform. Failure or damage inside the motor may lead to changes in the internal descent resistance of the motor, resulting in abnormally accelerated emergency descent speed.

When the emergency descent speed is abnormally accelerated, the ground operator should press the emergency descent knob to control platform descending speed and ensure the safety of the personnel on the working platform.

## 24. 5.2 Battery Maintenance





Proper battery condition is essential to good machine performance and operational safety. Improper fluid levels or damaged cables and connections can result in component damage and hazardous conditions.

This inspection is not required for machines with sealed or non-maintainable batteries.

Check electrolyte level of the battery every two weeks. Fully charge the battery before adding water. If the electrolyte level is much higher than the plate, then no need to add water.

### **⚠ CAUTION**

#### **Electric shock hazard:**

**Contact with hot or live circuits may result in death or serious injury. Remove all rings, watches and jewelry.**

#### **Body Injury Hazard:**

**Batteries contain acid. Avoid spilling or contacting battery acid. Neutralize battery acid spills with baking soda and water.**

**The battery should be fully charged before this inspection.**

- a) Only qualified riggers should rig the machine.
- b) Only certified crane operators should lift the machine and only in accordance with the applicable crane regulations.
- c) Be sure that the battery hold-down brackets are in place and secure.

Adding terminal protectors and a corrosion preventative sealant will help eliminate the corrosion on the battery terminals and cables.

## **25. 5.3 Regular Maintenance**

- a) Maintenance performed quarterly, annually and every two years must be completed by a person trained and qualified to perform maintenance on this machine according to the procedures found in the service manual for this machine.
- b) Machines that have been out of service for more than three months must receive the quarterly inspection before they are put back into service.
- c) By observing oil level in hydraulic oil tank, the hydraulic oil level after excluding air in the hydraulic system should reach the maximum scale mark on the hydraulic oil tank, and not be higher than bottom of the oil tank cap (different models have different maximum scale).
- d) Check the emergency lowering function every quarter.
- e) Inspect the wheel bolts for proper torque quarterly.



## SECTION 6 STORAGE AND EX-FACTORY TEST

### 26. 6.1 Storage Conditions

Ambient temperature for machine storage and transportation should be between -20°C/-4°F and 40°C/104°F, with relative humidity not greater than 85% and 100% only for short-term.

### 27. 6.2 Ex-factory Test Items

Machine must complete testing items in the following table before delivery:

**Table 6-1 Ex-factory testing items (ZS0607E Series)**

Tests Items	Load Testing		Testing Movement
Overload Test	120%	276kg/610 lbs	Platform Lifting
Functional Test	110%	253kg/558 lbs	Traveling & Platform Lifting
Braking Test	100%	230kg/510 lbs	Max Speed of Forward & Reverse Traveling

**Table 6-2 Ex-factory testing items (ZS0407E Series)**

Tests Items	Load Testing		Testing Movement
Overload Test	120%	288kg/635 lbs	Platform Lifting
Functional Test	110%	264kg/582 lbs	Traveling & Platform Lifting
Braking Test	100%	240kg/530 lbs	Max Speed of Forward & Reverse Traveling

TECHNICAL  
PARAMETER

## SECTION 7 TECHNICAL PARAMETER

Table 7-1 ZS0607E Series Technical parameter

Model	ZS0607 Series	Parameters	
<b>Dimension</b>	Work Height (Indoor)	7.8 m	25ft 7in
	Work Height (Outdoor)	6.4 m	20ft 12in
	Platform Height (Indoor)	5.8 m	19ft
	Platform Height (Outdoor)	4.4 m	14ft 5in
	Max Height (stowed position)	2.20 m	7ft 3in
	Max Platform Height (stowed position)	1.05 m	3ft 5in
	Max Height (Stowed, rails folded)	1.79 m	5ft 10in
	Rails Height	1.1 m	3ft 7in
	Overall Width	0.76 m	2ft 6in
	Overall Length (Stowed)	1.85 m	6ft 1in
	Extension Length	0.91 m	3ft
	Platform Size (Length ×Width)	1.65 × 0.74 m	5ft 5in×2ft 5in
	Wheelbase	1.37 m	4ft 6in
	Ground Clearance	0.06 m	2.4in
Pothole Guards deploy	0.016 m	0.65in	
<b>Working Performance</b>	Platform load rating Capacity	230 kg	510 lbs
	Max. Number of Workers	2 (Indoor)/1 (Outdoor)	
	Drive Speed (Stowed)	4 km/h	2.5 mph
	Drive Speed (Elevated)	0.8 km/h	0.5mph
	Maximum slope rating, stowed position	25% (14°)	
	Maximum Side Slope Rating in Stowed Position	25% (14°)	

**Table 7-1 ZS0607E Series Technical parameter**

Model	ZS0607 Series	Parameters	
<b>Working Environment</b>	Maximum chassis working Angle (longitudinal/lateral)	3°/1.5°	
	Turning Radius (Outside)	1.6 m	5ft 3in
	Turning Radius (Inside)	0.1 m	4in
	Gross Vibration Value of Scissor Arm	≤2.5 m/s	≤5.6 mph
	Highest square root of weighing acceleration bearing by the machine body	≤0.5 m/s <sup>2</sup>	≤1ft 8in /s <sup>2</sup>
	Wind Speed	12.5m/s	28.0mph
	Lowest Operating Temperature	-20°C	-4°F
	Highest Ambient Temperature	60°C	140°F
	SPL at Ground	<70 dBA	
	SPL at Platform	<70 dBA	
<b>Others</b>	Gross	1455 kg	3210 lbs
	Power	4 packs of batteries, 6V/170AH	
	Voltage	24V	
	Platform AC Power Socket	Standard	
	Tire specifications	Φ323mm×100mm	Φ13in×4in
	Tire Capacity	580 kg	1280 lbs
	Tire Contact Pressure	9.25 kg/cm <sup>2</sup>	132 psi
	Ground Pressure	0.11 kg/cm <sup>2</sup>	1.7 psi

**Table 7-2 ZS0407E Series Technical parameter**

<b>Model</b>	<b>ZS0407 Series</b>	<b>Parameters</b>	
<b>Dimension</b>	Work Height (Indoor)	6.25 m	20ft 6in
	Work Height (Outdoor)	4.25 m	13ft 11in
	Platform Height (Indoor)	4.25 m	13ft 11in
	Platform Height (Outdoor)	3.6 m	11ft 10in
	Max Height (stowed position)	2.05 m	6ft 9in
	Max Platform Height (stowed position)	0.96 m	3ft 1in
	Max Height (Stowed, rails folded)	1.70 m	5ft 7in
	Rails Height	1.1 m	3ft 7in
	Overall Width	0.76 m	2ft 6in
	Overall Length (Stowed)	1.44 m	4ft 9in
	Extension Length	0.60 m	2ft
	Platform Size (Length ×Width)	1.29 × 0.7 m	4ft 3in×2ft 4in
	Wheelbase	1.05 m	3ft 5in
	Ground Clearance	0.06 m	2.4in
Pothole Guards deploy	0.017 m	0.65in	
<b>Working Performance</b>	Platform load rating Capacity	240 kg	530 lbs
	Max. Number of Workers	2 (Indoor)/1(Outdoor)	
	Drive Speed (Stowed)	4 km/h	2.5 mph
	Drive Speed (Elevated)	0.8 km/h	0.5mph
	Maximum slope rating, stowed position	30% (17°)	
	Maximum Side Slope Rating in Stowed Position	30% (17°)	
	Maximum chassis working Angle (longitudinal/lateral)	3°/1.5°	

**Table 7-2 ZS0407E Series Technical parameter**

Model	ZS0407 Series	Parameters	
<b>Working Environment</b>	Turning Radius (Outside)	1.6 m	5ft 3in
	Turning Radius (Inside)	0.4 m	1ft 4in
	Gross Vibration Value of Scissor Arm	≤2.5 m/s	≤5.6 mph
	Highest square root of weighing acceleration bearing by the machine body	≤0.5 m/s <sup>2</sup>	≤1ft 8in /s <sup>2</sup>
	Wind Speed	12.5 m/s	28 mph
	Lowest Operating Temperature	-20°C	-4°F
	Highest Ambient Temperature	60°C	140°F
	SPL at Ground	<70 dBA	
	SPL at Platform	<70 dBA	
<b>Others</b>	Gross	920 kg	2028 lbs
	Power	2 packs of batteries, 12V/85AH (E) Lithium-ion battery, 80AH (E-Li)	
	Voltage	24V	
	Platform AC Power Socket	Standard	
	Tire specifications	Φ230mm×80mm	Φ9in×3in
	Tire Capacity	390kg	860 lbs
	Tire Contact Pressure	8.5 kg/cm <sup>2</sup>	121 psi
	Ground Pressure	0.11 kg/cm <sup>2</sup>	1.7 psi



# **ZOOMLION**

**Operation and Safety Manual**

**Section 8 Disposal**





## SECTION 8 DISPOSAL

### **28. 8.1 Service life**

- m) For 10 years.
- n) Please doing complete inspection for every 5years.

### **29. 8.2 Disposal**

- o) If the MEWP cannot be repaired, please follow your national regulation to dispose the MEWP.



### **Appendix: Inspection and Maintenance Records**

<b>Date</b>	<b>record</b>

### Appendix: Inspection and Maintenance Records

Date	record